

The product using material and processing must conform to the "WI-PZ-142"HSF technical standard control requirements

RoHS

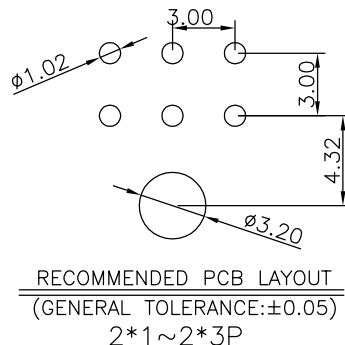
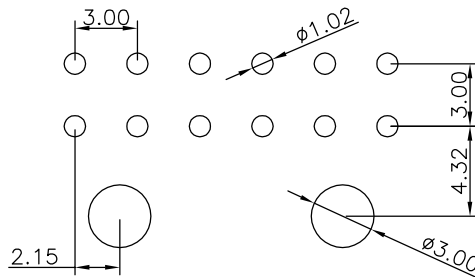
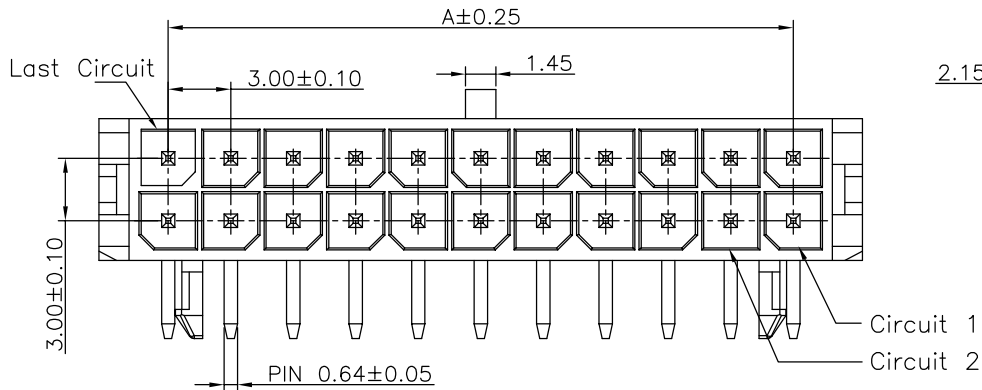

NOTE:
1.MATERIAL SPECIFICATION:
1-1.HOUSING:LCP NATURE UL94V-0
1-2.CONTACTS: BRASS
1-3.SOLDER:BRASS
2.PLATING SPECIFICATION:
2-1.CONTACTS:
TIN/AU PLATED OVER ALL.
3.ELECTRICAL PERFORMANCE:
3-1. RATED CURRENT : 5A AC,DC
3-2.INSULATION RESISTANCE: 00m Ω MIN
3-3.CONTACT RESISTANCE : 10m Ω (MAX.)
3-4.WITHSTANDING VOLTAGE: 1000V AC/minute
4.ENVIRONMENTAL PERFORMANCE:
OPERATING TEMPERATURE: $-40^{\circ}C \sim +105^{\circ}C$.

$\Delta 1$ C3030 W 9-2 XX 1 X X 0
SERIES NO:
CONNECTOR:
W-WAFER
ANGLE:
9-90°
ROW NO:
2-DOUBLE ROW
PIN Q'PY:
02~24
COLOR:
A-BLACK
S-NATURE
PLATING:
A-ALL AU G/F
C-BRIGHT TIN
D-MATTE Tin
TERMIPOINT:
1-DIP

Ordering Information & Dimensions

Circuit	Dimensions (mm)		
	A	B	C
2*01	---	6.65	3.55
2*02	3.00	9.65	3.55
2*03	6.00	12.65	3.55
2*04	9.00	15.65	8.30
2*05	12.00	18.65	11.30
2*06	15.00	21.65	14.30
2*07	18.00	24.65	17.30
2*08	21.00	27.65	20.30
2*09	24.00	30.65	23.30
2*10	27.00	33.65	26.30
2*11	30.00	36.65	29.30
2*12	33.00	39.65	32.30

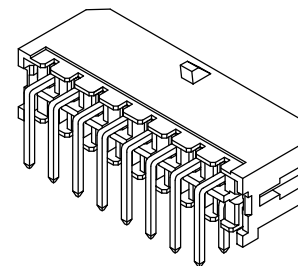
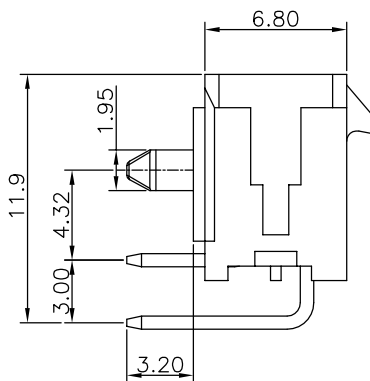
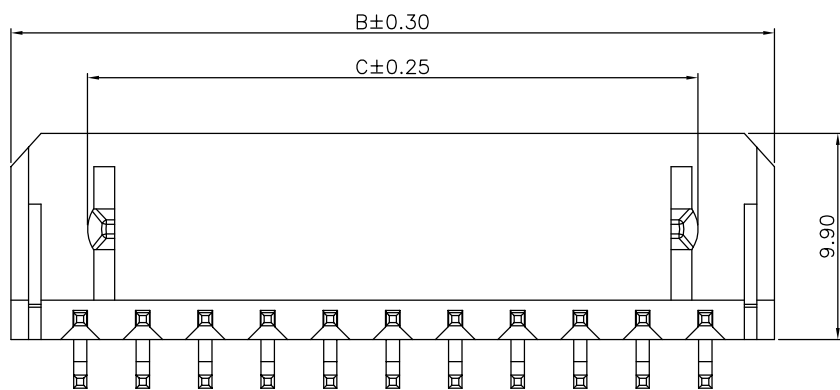

REV.	REVISION RECORD	DATE	GENERAL TOLERANCES		SCALE:	NAME	DATE	PART.NO:	DWG.NO:
AO	NEW RELEASE	21.01.13	LINEAR	ANGLES	1:1	Wang_jr	23.09.14	C3030W9-2XX1XX0	ENDE05
A1	PART NUMBER RENEWAL	23.09.14	0.00 \pm 0.35	X'REF \pm 6'		Wang_jr	23.09.14		
			0.00 \pm 0.25	X' \pm 3'		LX_HOU	23.09.14	TITLE: 3.00mm Pitch 90° Double Row Wafer	
			0.000 \pm 0.10	X'X' \pm 2'					REV: A1 SHEET: 1/3



WanLian Technology Co., Ltd

The product using material and processing must conform to the "WI-PZ-142"HSF technical standard control requirements

RoHS

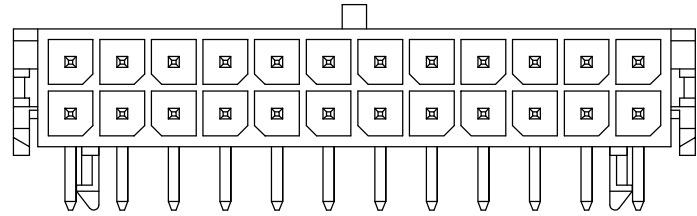

2X12P

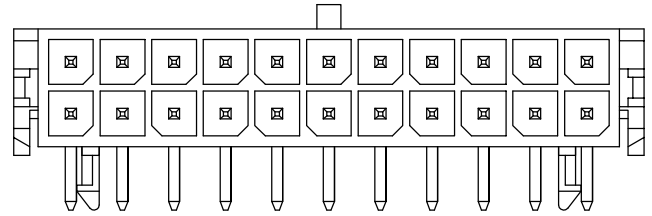

2X11P

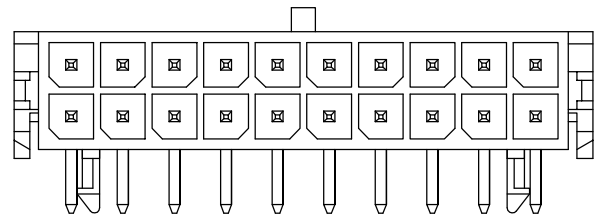

2X10P

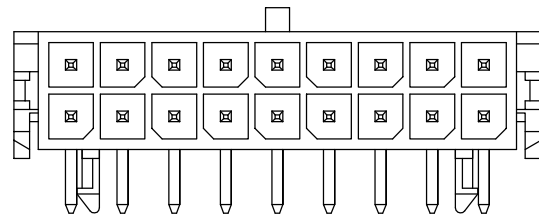

2X09P

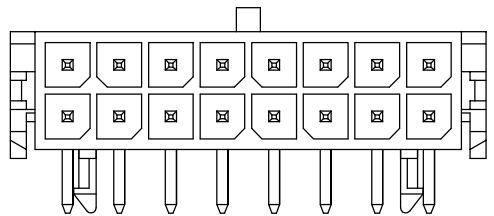

2X08P

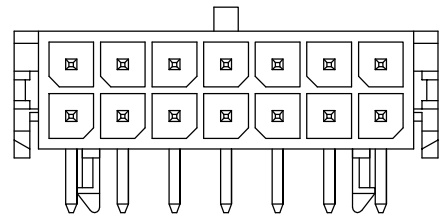

2X07P

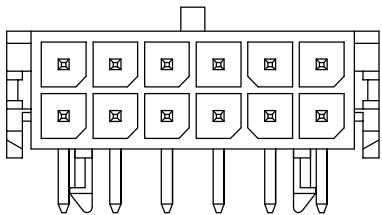

2X06P

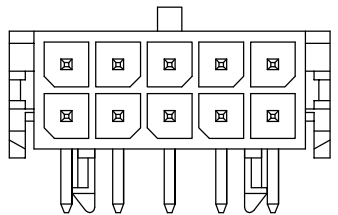

2X05P

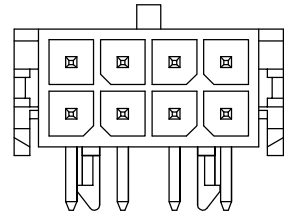

2X04P

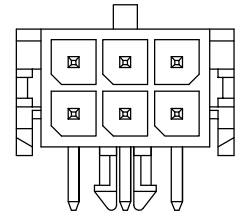

2X03P

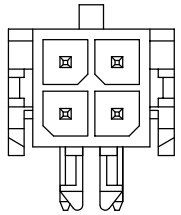

2X02P

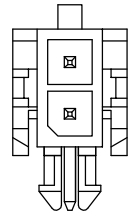

2X01P

REV.	REVISION RECORD	DATE		GENERAL TOLERANCES		SCALE: 1:1	NAME	DATE	PART.NO: C3030W9-2XX1XX0	DWG.NO: ENDE05	 WanLian Technology Co., Ltd
A0	NEW RELEASE	21.01.13		LINEAR	ANGLES	APPROVED	Wang_jr	23.09.14			
A1	PART NUMBER RENEWAL	23.09.14		0.0±0.35	X'REF±6°	DESIGNER	Wang_jr	23.09.14	TITLE:		
				UNIT:mm	0.00±0.25	X'±3°	DRAWN	LX_HOU	23.09.14	3.00mm Pitch 90° Double Row Wafer	
			SIZE: A4	0.000±0.10	X'X' ±2°						

The product using material and processing must conform to the "WI-PZ-142"HSF technical standard control requirements

RoHS

包装说明:

- 1、注意产品方向不可放反且需一致;
- 2、每10盘产品为一扎, 一盘一盖, 然后用PE膜缠绕; 套入防水袋 (2扎)
- 3、装箱与贴标签, 注意产品不可少数、多数、方向需一致;
- 4、外箱包装均需贴对应产品标签, 尾数箱需用不影响品质之物品填充, 并注明尾数。

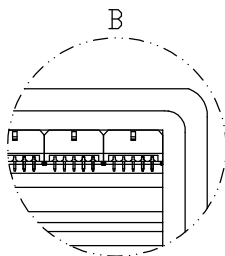
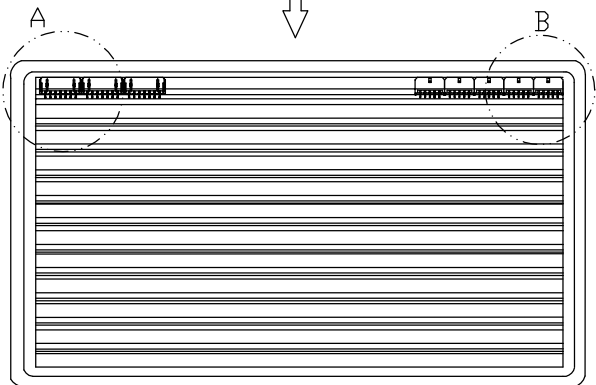
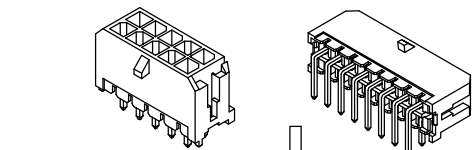

180度DIP摆放方向
(卡点朝上)



1680	84	2X12P
1920	96	2X11P
2160	108	2X10P
2160	108	2X9P
2640	132	2X8P
2880	144	2X7P
3360	168	2X6P
3840	192	2X5P
4560	228	2X4P
5760	288	2X3P
7440	372	2X2P
10800	540	2X1P
PCS/Cartron	PCS/Tray	POS

示图一(底盘):

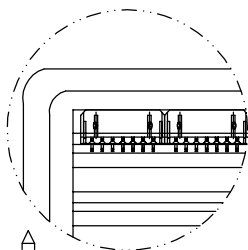

90度DIP摆放方向
(卡点朝下)

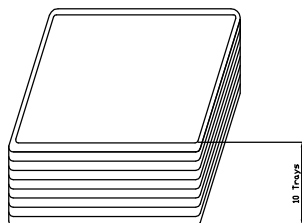

示图三: 10盘/扎

示图二: 盖子(1盘一盖)

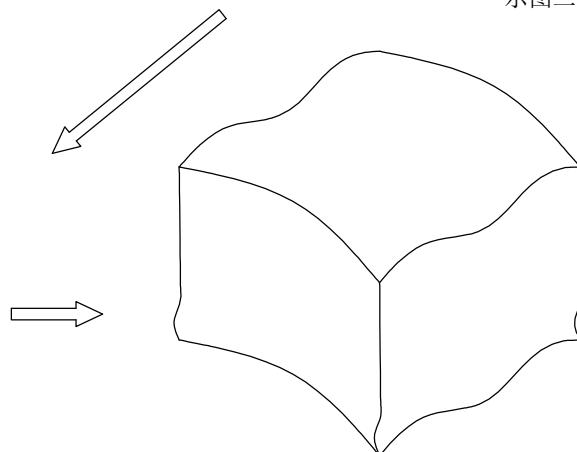

示图四: 防水袋, (55+19)*61CM 四方袋(防水袋)(一袋/2扎)

ADHESIVE TAPE

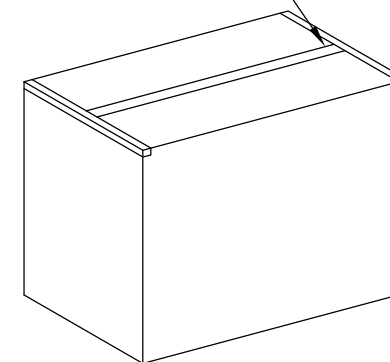

示图五: 纸箱35*28.5*32CM(一箱/2扎)

REV.	REVISION RECORD	DATE		GENERAL TOLERANCES		SCALE: 1:1	NAME	DATE	PART.NO: C3030W9-2XX1XX0	DWG.NO: ENDE05	 WanLian Technology Co., Ltd	
A0	NEW RELEASE	21.01.13		LINEAR	ANGLES	APPROVED	Wang_jr	23.09.14				
A1	PART NUMBER RENEWAL	23.09.14	UNIT:mm	0.00±0.25	X'±3'	DESIGNER	Wang_jr	23.09.14	TITLE: 3.00mm Pitch 90° Double Row Wafer		REV: A1	SHEET: 3/3
			SIZE: A4	0.000±0.10	X'X' ±2'	DRAWN	LX_HOU	23.09.14				