

The product using material and processing must conform to the "WI-PZ-142"HSF technical standard control requirements

RoHS+HF

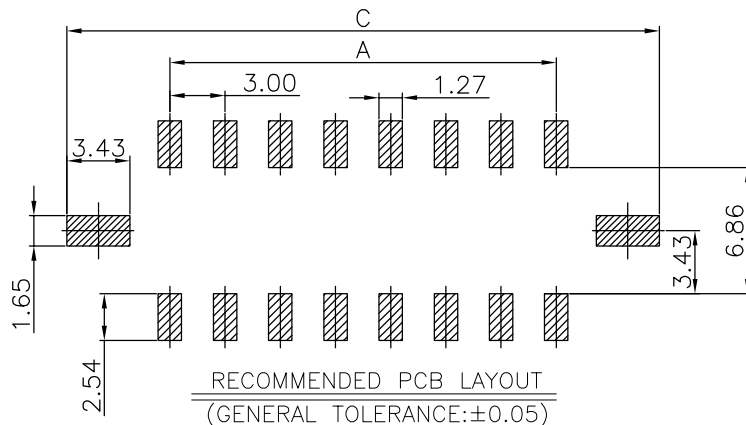
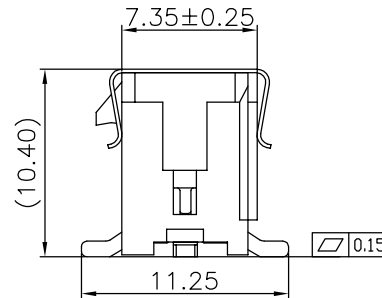
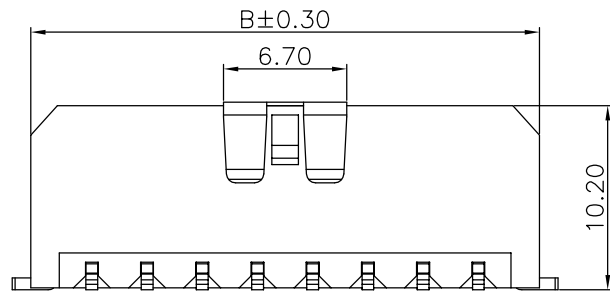
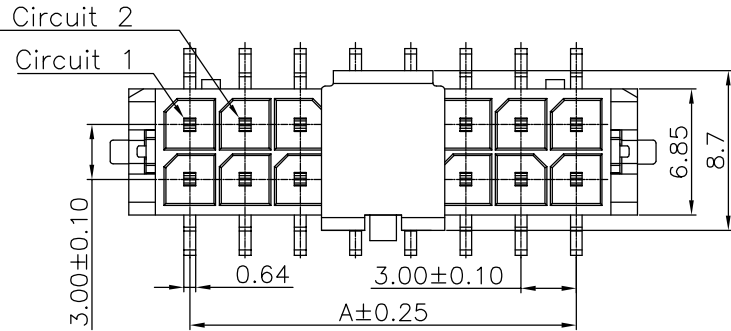

NOTE:

1.MATERIAL SPECIFICATION:

- 1-1.HOUSING: LCP NATURE UL94V-0, BLACK
- 1-2.CONTACTS: BRASS
- 1-3.SOLDER TABS: BRASS

2.PLATING SPECIFICATION:

- 2-1.CONTACTS: TIN PLATED OVER ALL.

3.ELECTRICAL PERFORMANCE:

- 3-1. RATED CURRENT : 5A AC,DC
- 3-2.INSULATION RESISTANCE: 1000MΩ MIN
- 3-3.CONTACT RESISTANCE : 10mΩ(MAX.)
- 3-4.WITHSTANDING VOLTAGE: 1000V AC/minute

4.ENVIRONMENTAL PERFORMANCE:

- OPERATING TEMPERATURE: -40°C~+105°C.

5.PACKAGE SPEC: REEL

6.PART.NO:

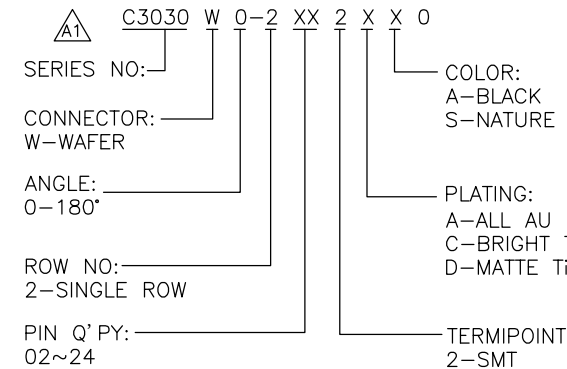

Circuit	Dimensions(mm)			Circuit	Dimensions(mm)		
	A	B	C		A	B	C
2*01	---	6.65	11.20	2*07	18.00	24.65	29.20
2*02	3.00	9.65	14.20	2*08	21.00	27.65	32.20
2*03	6.00	12.65	17.20	2*09	24.00	30.65	35.20
2*04	9.00	15.65	20.20	2*10	27.00	33.65	38.20
2*05	12.00	18.65	23.20	2*11	30.00	36.65	41.20
2*06	15.00	21.65	26.20	2*12	33.00	39.65	44.20

REV.	REVISION RECORD	DATE	GENERAL TOLERANCES		SCALE:	NAME	DATE	PART.NO:	DWG.NO:	 WanLian Technology Co., Ltd
A0	NEW RELEASE	21.01.13	LINEAR	ANGLES	1:1	Wang_jr	23.09.14	C3030W0-2XX2XX0	ENDE05	
A1	PART NUMBER RENEWAL	23.09.14	0.0±0.35	X'REF±6'	APPROVED	Ding_bo	23.09.14	TITLE:	REV: A1	
			0.00±0.25	X'±3'	DESIGNER	LX_HOU	23.09.14	3.00mm Crimp Style connectors	SHEET: 1/3	
			UNIT:mm	X'X' ±2'	DRAWN					
			SIZE: A4	0.000±0.10						

The product using material and processing must conform to the "WI-PZ-142"HSF technical standard control requirements

RoHS+HF

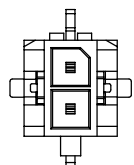

2*01PIN

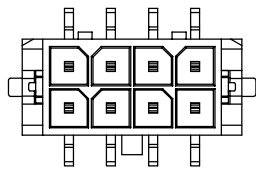

2*04PIN

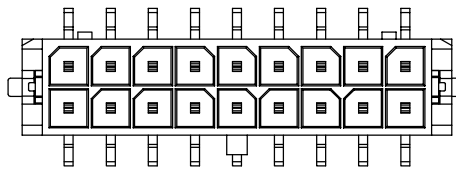

2*09PIN

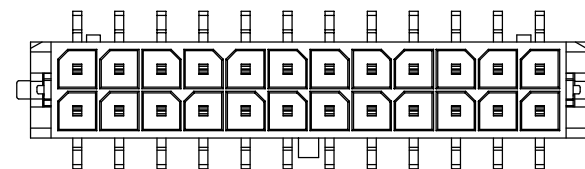

2*12PIN

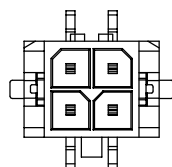

2*02PIN

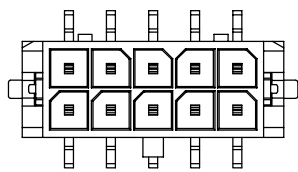

2*05PIN

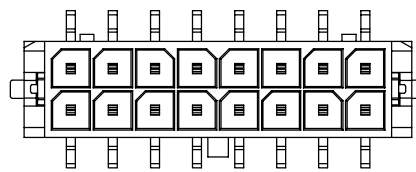

2*08PIN

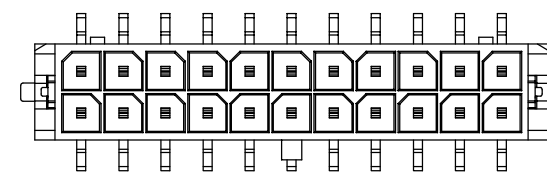

2*11PIN

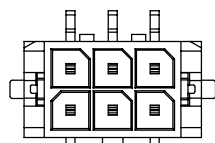

2*03PIN

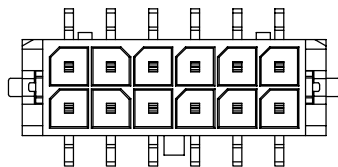

2*06PIN

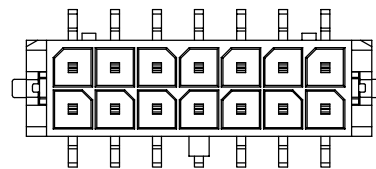

2*07PIN

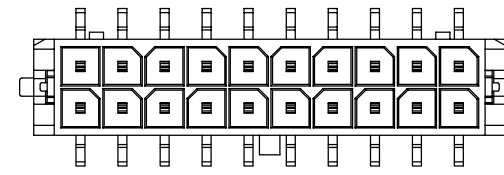

2*10PIN

REV.	REVISION RECORD	DATE		GENERAL TOLERANCES		SCALE: 1:1	NAME	DATE	PART.NO: C3030W0-2XX2XX0	DWG.NO: ENDE05	 WanLian Technology Co., Ltd
A0	NEW RELEASE	21.01.13		LINEAR	ANGLES	APPROVED	Wang_jr	23.09.14	TITLE: 3.00mm Crimp Style connectors	REV: A1	
A1	PART NUMBER RENEWAL	23.09.14	UNIT:mm	0.00±0.25	X'±3'	DESIGNER	Ding_bo	23.09.14			
			SIZE: A4	0.000±0.10	X'X' ±2'	DRAWN	LX_HOU	23.09.14			

The product using material and processing must conform to the "WI-PZ-142"HSF technical standard control requirements

RoHS+HF

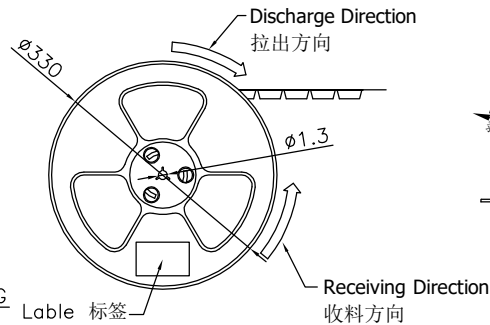
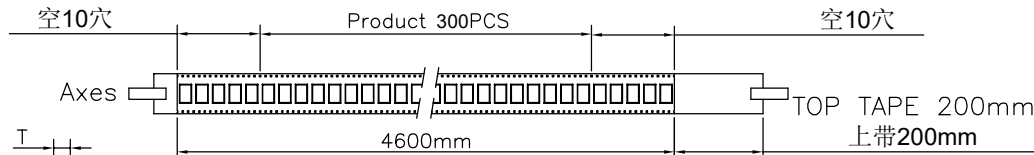

COVER TAPE PEEL STRENGTH:20~120g
上带剥离力量: 20~120g
速度 PEEL SPEED:300mm/minute

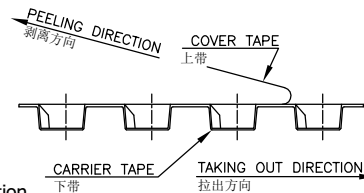

Single hole: None Hole Side
单孔: 贴无链孔侧
Double hole: Elliptical Hole Side
双孔: 贴椭圆孔侧

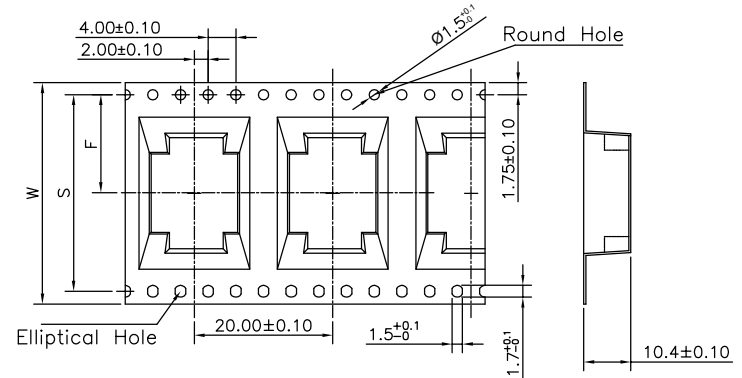
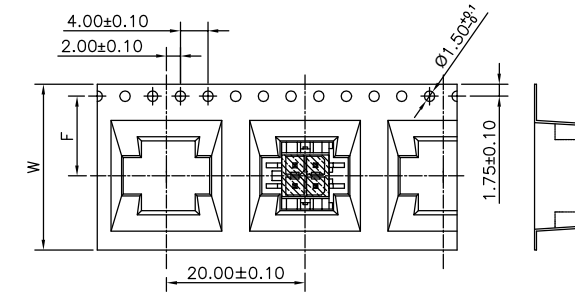

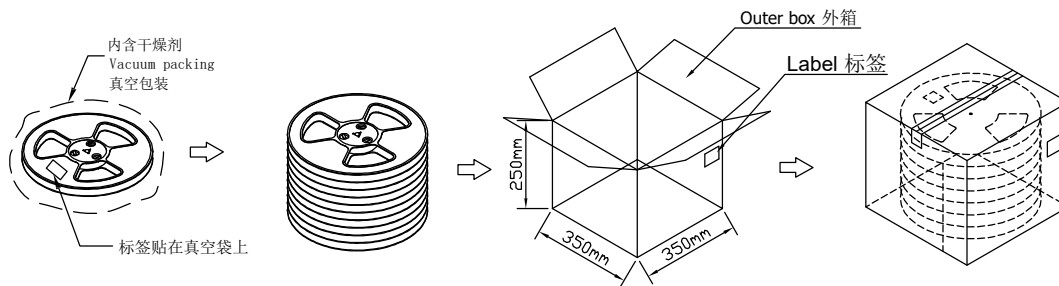

MPQ:300PCS

Circuit	W	S	F	T	G	REEL /PCS	CARTON /R	CARTON /PCS
2*1	24	/	11.50	27.0	25.4	300	12	3600
2*2	32	28.4	14.20	35.0	33.4	300	9	2700
2*3								
2*4								
2*5	44	36.4	18.20	48.5	44.4	300	7	2100
2*6								
2*7								
2*8	56	52.4	26.20	60.5	56.4	300	5	1500
2*9								
2*10								
2*11	72	68.4	34.20	76	72.4	300	4	1200
2*12								



Note:

- Carrier Camber Is Within 1mm In 100mm ; 带长100mm内容许弯曲度1mm
- 10 Sprocket Hole Pitch Cumulative Tolerance ± 0.2 MM ; 圆孔十个孔距离累计允许公差为 ± 0.2 mm
- Carrier Tape Material for PS ; 下带材质为PS材质; Color颜色: Black黑色
- Thickness=0.40 ± 0.05 ; 材料厚度为0.40 ± 0.05 mm

REV.	REVISION RECORD	DATE	GENERAL TOLERANCES		SCALE:	NAME	DATE	PART.NO:	DWG.NO:	 WanLian Technology Co., Ltd
A0	NEW RELEASE	21.01.13		LINEAR	1:1	Wang_jr	23.09.14	C3030W0-2XX2XX0	ENDE05	
A1	PART NUMBER RENEWAL	23.09.14		ANGLES	APPROVED					
			UNIT:mm	0.00 ± 0.25	X $\pm 3^{\circ}$	DESIGNER	Ding_bo	23.09.14	TITLE:	
			SIZE: A4	0.000 ± 0.10	X \times X $\pm 2^{\circ}$	DRAWN	LX_HOU	23.09.14	3.00mm Crimp Style connectors	

REV: A1 SHEET: 3/3