

The product using material and processing must conform to the "WI-PZ-142"HSF technical standard control requirements

RoHS+HF

NOTE:

- 1.MATERIAL SPECIFICATION:
1-1.HOUSING: LCP NATURE UL94V-0, BLACK
1-2.CONTACTS: BRASS
- 2.PLATING SPECIFICATION:
2-1.CONTACTS:
TIN PLATED OVER ALL.
- 3.ELECTRICAL PERFORMANCE:
3-1. RATED CURRENT : 5A AC,DC
3-2.INSULATION RESISTANCE: 1000MΩ MIN
3-3.CONTACT RESISTANCE : 10mΩ(MAX.)
3-4.WITHSTANDING VOLTAGE: 1000V AC/minute
- 4.ENVIRONMENTAL PERFORMANCE:
OPERATING TEMPERATURE: -40°C~+105°C.
- 5.PACKAGE SPEC: REEL
- 6.PART.NO:

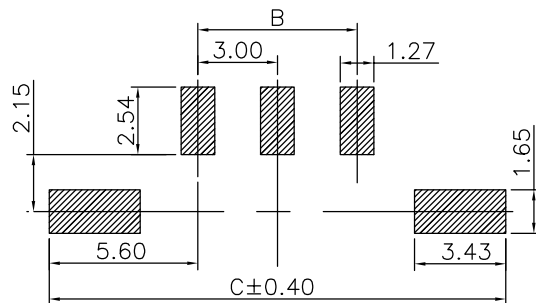
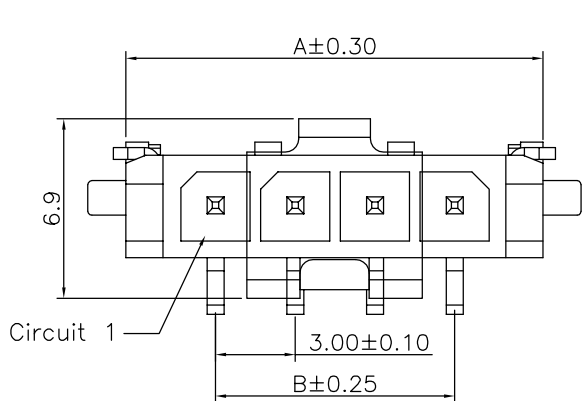

RECOMMENDED PCB LAYOUT
(GENERAL TOLERANCE:±0.05)

SERIES NO: C3030 W 0-1 XX 2 X X 0
 CONNECTOR: W-WAFER
 ANGLE: 0-180°
 ROW NO: 1-SINGLE ROW
 PIN Q'PY: 02~12

COLOR:
A-BLACK
S-NATURE

PLATING:
A-ALL AU G/F
C-BRIGHT TIN
D-MATTE TIN

TERMPOINT:
2-SMT

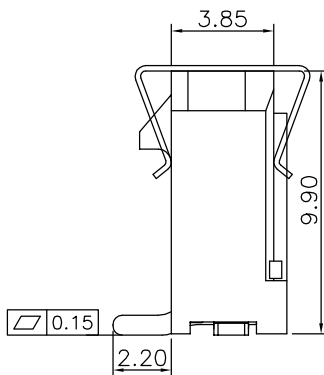
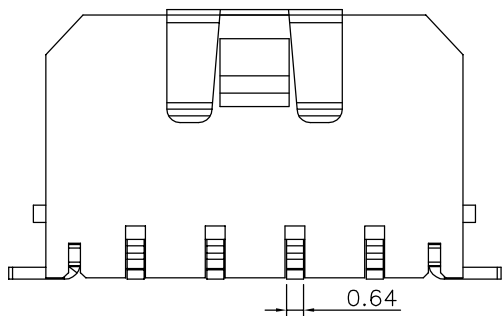

Circuit	Dimensions(mm)		
	A	B	C
02	9.70	3.00	14.20
03	12.70	6.00	17.20
04	15.70	9.00	20.20
05	18.70	12.00	23.20
06	21.70	15.00	26.20
07	24.70	18.00	29.20
08	27.70	21.00	32.20
09	30.70	24.00	35.20
10	33.70	27.00	38.20
11	36.70	30.00	41.20
12	39.70	33.00	44.20

REV.	REVISION RECORD	DATE	GENERAL TOLERANCES		SCALE:	NAME	DATE	PART.NO:	DWG.NO:
A0	NEW RELEASE	21.01.13	LINEAR	ANGLES	1:1	Wang_jr	23.09.13	C3030W0-1XX2XX0	ENDE05
A1	HOLE POSITION CHANGE	23.07.25	0.0±0.35	X'REF±6°	APPROVED	Ding_bo	23.09.13	TITLE: 3.00mm Pitch 180° SMT Wafer	REV: A2 SHEET: 1/3
A2	PART NUMBER RENEWAL	23.09.13	0.00±0.25	X'±3°	DESIGNER	LX_HOU	23.09.13		
			0.000±0.10	X'X' ±2°	DRAWN				





The product using material and processing must conform to the "WI-PZ-142"HSF technical standard control requirements

RoHS+HF

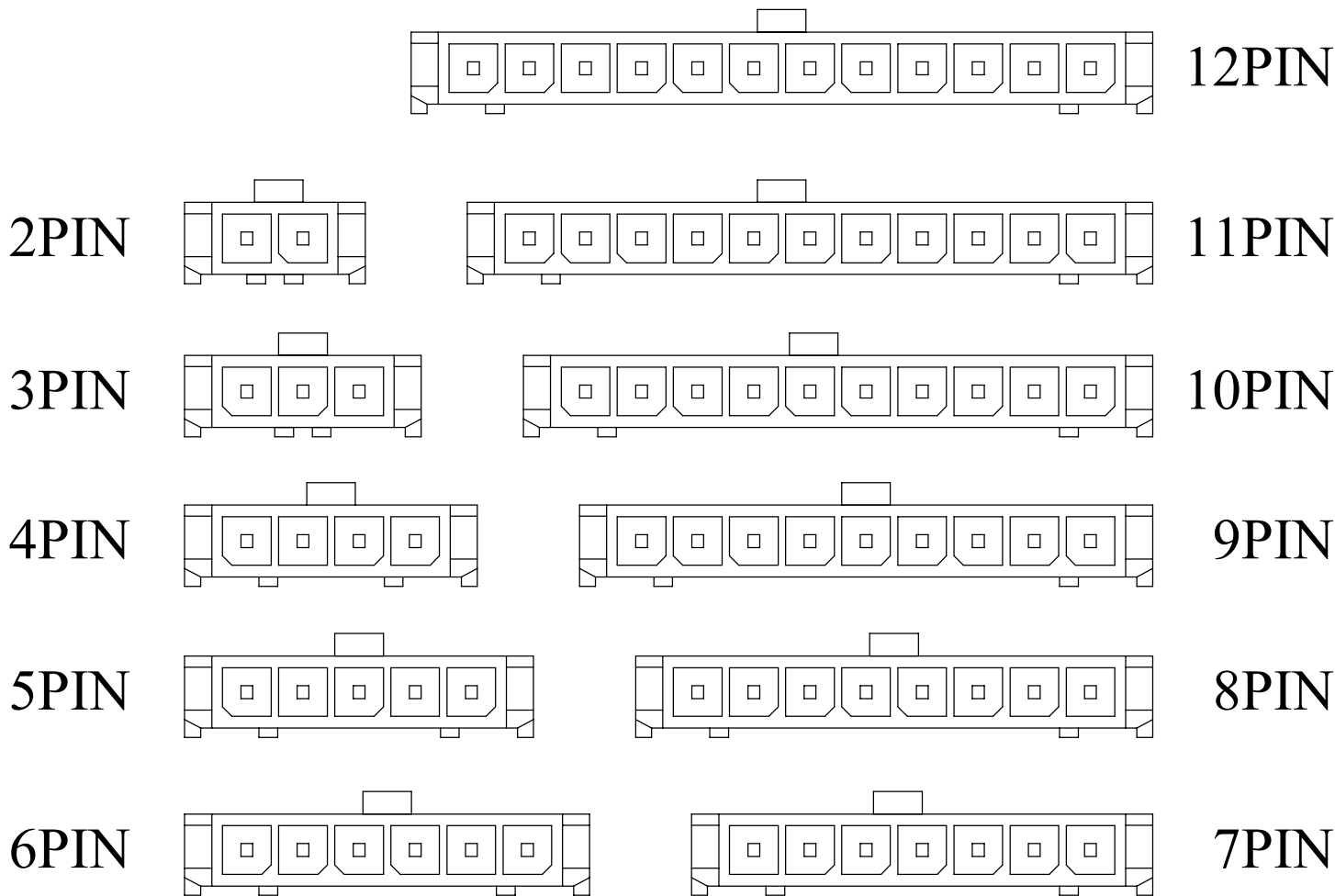
孔位图



REV.	REVISION RECORD	DATE		GENERAL TOLERANCES		SCALE: 1:1	NAME	DATE	PART.NO:	DWG.NO:		
A0	NEW RELEASE	21.01.13		LINEAR	ANGLES	APPROVED	Wang_jr	23.09.13	C3030W0-1XX2XX0	ENDE05		
A1	HOLE POSITION CHANGE	23.07.25	UNIT:mm	0.0±0.35	X'REF±6°	DESIGNER	Ding_bo	23.09.13	TITLE: 3.00mm Pitch 180° SMT Wafer		REV: A2	SHEET: 2/3
A2	PART NUMBER RENEWAL	23.09.13		0.00±0.25	X'±3°	DRAWN	LX_HOU	23.09.13				
			SIZE: A4	0.000±0.10	X'X' ±2°							

The product using material and processing must conform to the "WI-PZ-142" HSF technical standard control requirements

RoHS+HF

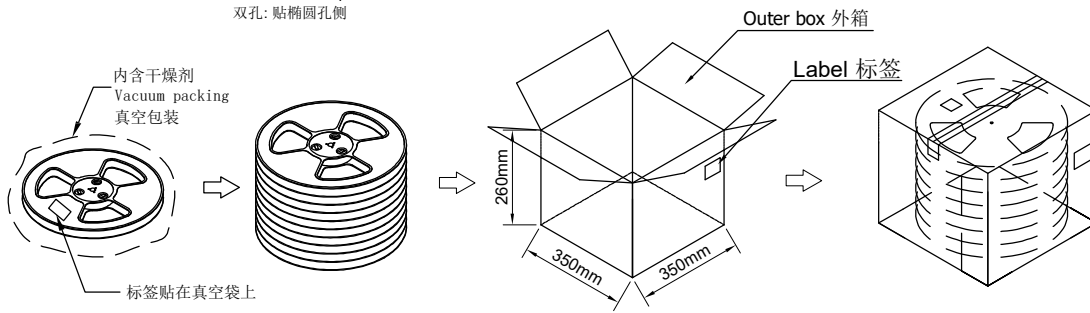
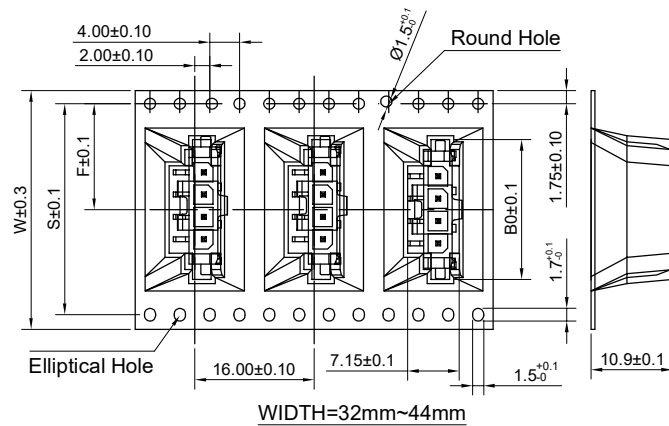
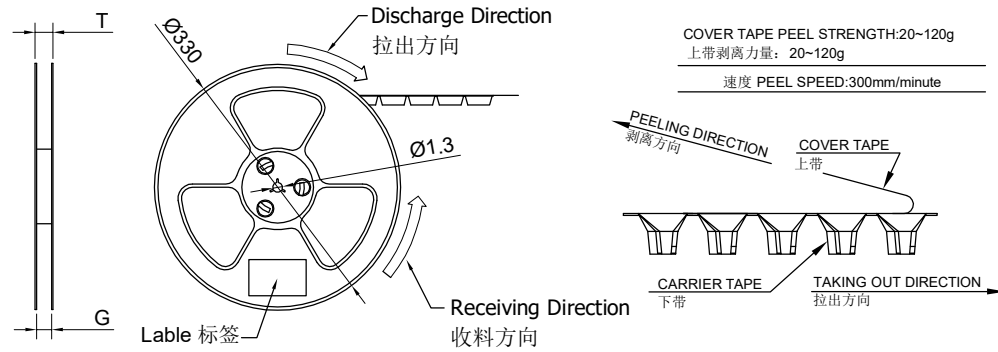
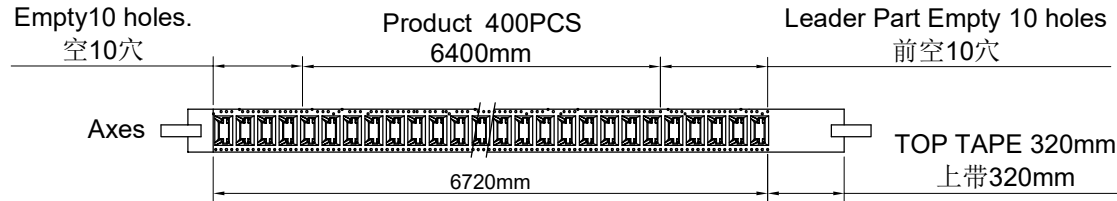

- Note:**
- Carrier Camber Is Within 1mm In 100mm ; 带长100mm内容许弯曲度1mm
 - 10 Sprocket Hole Pitch Cumulative Tolerance±0.2MM ; 圆孔十个孔距离累计允许公差为±0.2mm
 - Carrier Tape Material for PS ; 下带材质为PS材质; Color颜色: Black黑色
 - bracer保护带: Color颜色:Natural透明色;厚度0.40mm最小
 - Thickness=0.50±0.05 ; 材料厚度为0.50±0.05mm

Circuit	W	S	F	T	G	Cover Tape(宽规) 上带(W)	Carrier Tape(Color) 下带(颜色)	B0	REEL /PCS	CARTON /R	CARTON /PCS
03	32	28.4	14.20	35.0	33.5	25.5		16.4	6	2400	
04	32	28.4	14.20	35.0	33.5	25.5		19.4	6	2400	
05	44	40.4	20.20	47.0	45.5	37.5		22.4	5	2000	
06	44	40.4	20.20	47.0	45.5	37.5		25.4	5	2000	
07	44	40.4	20.20	47.0	45.5	37.5		28.4	5	2000	
08	44	40.4	20.20	47.0	45.5	37.5		31.4	5	2000	
09	56	52.4	26.20	59.00	57.5	49.5		34.4	4	1600	
10	56	52.4	26.20	59.00	57.5	49.5		37.4	4	1600	
11	56	52.4	26.20	59.00	57.5	49.5		40.4	4	1600	
12	56	52.4	26.20	59.00	57.5	49.5		43.4	4	1600	

REV.	REVISION RECORD	DATE	UNIT:mm	GENERAL TOLERANCES		SCALE: 1:1	NAME	DATE	PART.NO:	DWG.NO:	REV: A2	SHEET: 3/3
A0	NEW RELEASE	21.01.13		LINEAR	ANGLES	APPROVED	Wang_jr	23.09.13	C3030W0-1XX2XX0	ENDE05		
A1	HOLE POSITION CHANGE	23.07.25	0.00±0.25	X°REF±6°	DESIGNER	Ding_bo	23.09.13	TITLE:	3.00mm Pitch 180° Wafer REEL Packing			
A2	PART NUMBER RENEWAL	23.09.13	0.000±0.10	X°X° ±2°	DRAWN	LX_HOU	23.09.13					

WanLian Technology Co., Ltd