

The product using material and processing must conform to the "WI-PZ-001"HSF technical standard control requirements

RoHS

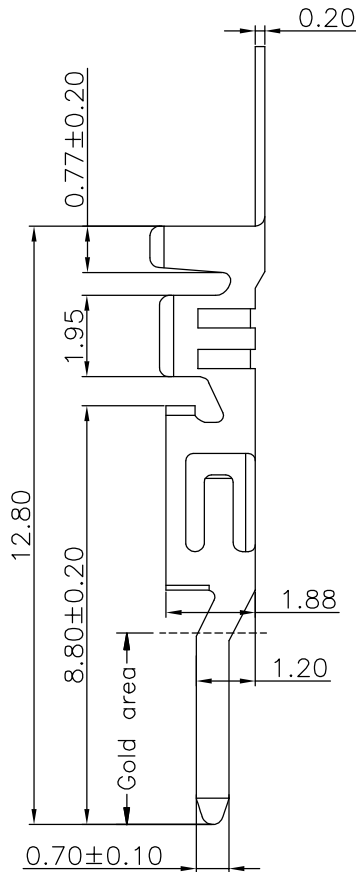
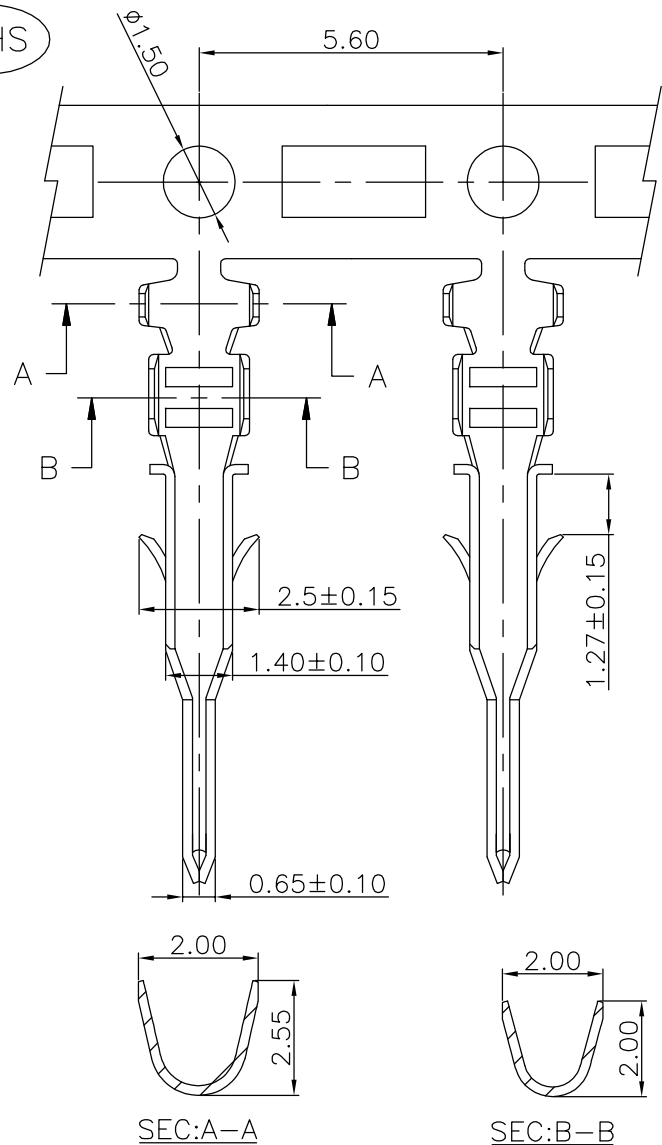

NOTE:

- 1.MATERIAL SPECIFICATION:
 - 1-1.TERMINAL: PHOSPHOR BRONZE
- 2.PLATING SPECIFICATION:
 - 2-1.TERMINAL: TIN/GOLD FLASH PLATED OVER ALL.
- 3.ELECTRICAL PERFORMANCE:
 - 3-1.CURRENT RATING: 5A
 - 3-2.CONTACT RESISTANCE: 10 mΩ MAX
 - 3-3.INSULATION RESISTANCE: 1000MΩ Min
 - 3-4.DIELECTRIC WITHSTANDING : 1000V
- 4.ENVIRONMENTAL PERFORMANCE:
 - 4-1.OPERATING TEMPERATURE: -25°C~+85°C.
- 5.PACKAGE SPEC: REEL
- 6.P/N:

SERIES NO: C3030 T M X-X
 CONNECTOR: T-TERMINAL
 MALE FEMALE: M-MALE
 PLATING:
 1-G/F
 A-ALL AU G/F
 C-BRIGHT TIN
 D-MATTE TIN
 METAL:
 P-PHOSPHOR BRONZE
 B-BRASS

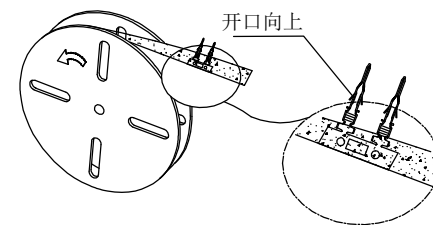

Ordering Information & Specifications

Part No	Wire Range	Qty/reel
C3030TMX-X	AWG#20-#24	10,000pcs

REV.	REVISION RECORD	DATE	GENERAL TOLERANCES		SCALE:	NAME	DATE	PART.NO:	DWG.NO:
AO	NEW RELEASE	21.10.12	LINEAR	ANGLES	1:1	Wang_jr	21.10.12	C3030TMX-X	ENDE05
			0.0±0.35	X'REF±6'	APPROVED	Han_Gao	21.10.12	TITLE: Pitch3.00mm 公端子 AWG20#~24#	
			0.00±0.25	X'±3'	DESIGNER	Zijun_Huang	21.10.12		
			0.000±0.10	X'X' ±2'	DRAWN				
			UNIT:mm					REV: A0	SHEET: 1/1
			SIZE: A4						

