

The product using material and processing must conform to the "WI-PZ-001"HSF technical standard control requirements

RoHS

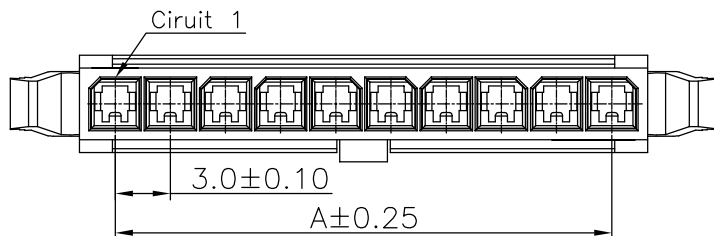

NOTE:  
 1.MATERIAL SPECIFICATION:  
 1-1.HOUSING: PA66  
 2.ELECTRICAL PERFORMANCE:  
 2-1.INSULATION RESISTANCE: 1000MΩ Min  
 2-2.DIELECTRIC WITHSTANDING : 1000V  
 3.ENVIRONMENTAL PERFORMANCE:  
 3-1.OPERATING TEMPERATURE: -25°C~+85°C.  
 4.PACKAGE SPEC: PE BAG  
 5.P/N:

SERIES NO: C3030 H F-1 XX X X  
 CONNECTOR: H HOUSING  
 MALE FEMALE: F-FEMALE  
 ROW NO: 1-SINGLE ROW  
 HOUSING:  
 1-UL94V-0  
 2-UL94V-2  
 COLOR:  
 A-BLACK  
 S-NATURE  
 PIN Q' PY:  
 02~12

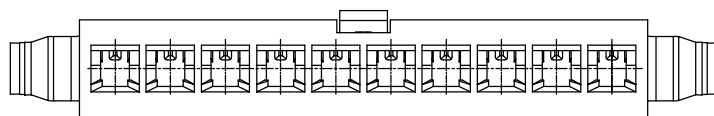
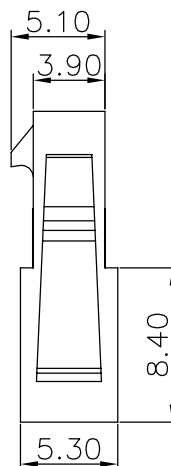
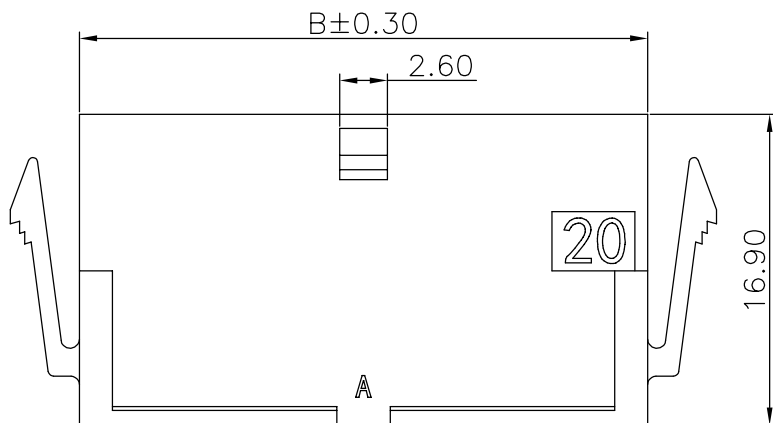
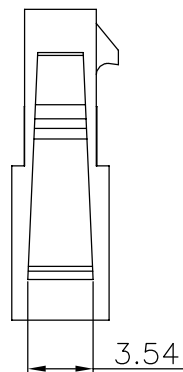

Ordering Information & Dimensions

Circuit	Dimensions(mm)		Circuit	Dimensions(mm)	
	A	B		A	B
02	3.00	6.95	08	21.00	24.95
03	6.00	9.95	09	24.00	27.95
04	9.00	12.95	10	27.00	30.95
05	12.00	15.95	11	30.00	33.95
06	15.00	18.95	12	33.00	36.95
07	18.00	21.95			

REV.	REVISION RECORD	DATE	UNIT:mm	GENERAL TOLERANCES		SCALE: 1:1	NAME	DATE	PART.NO:	DWG.NO:	 WanLian Technology Co., Ltd
A0	NEW RELEASE	21.10.12		SIZE: A4	LINEAR 0.00±0.25	ANGLES X'±3'	APPROVED	Wang_jr	21.10.12	C3030HF-1XXXX	
				0.00±0.10	X'X' ±2'	DESIGNER	Han_Gao	21.10.12	TITLE:		REV: A0
						DRAWN	Zijun_Huang	21.10.12	Pitch3.00mm 180°单排带扣带翅膀母胶壳		SHEET: 1/2

The product using material and processing must conform to the "WI-PZ-001"HSF technical standard control requirements

RoHS

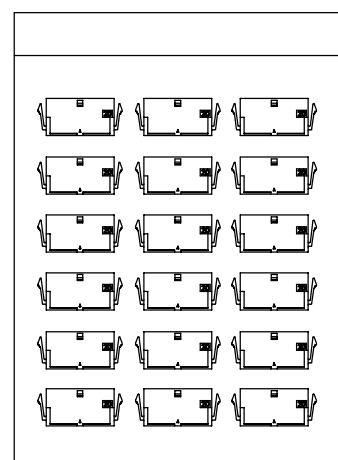
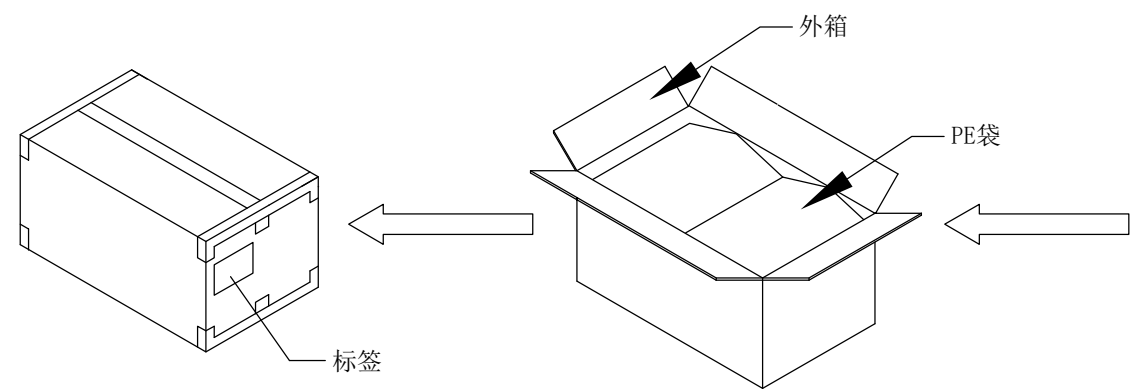
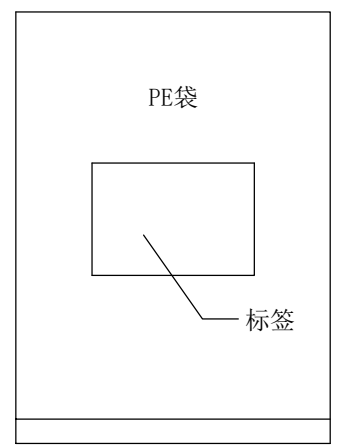
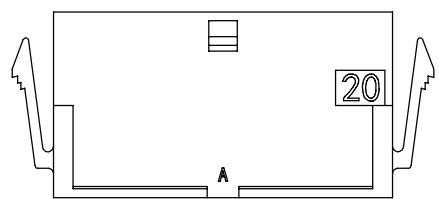

Circuit	Bag Pcs	CARTON Bag	CARTON Pcs
02	1K	30	30K
03	1K	30	30K
04	1K	30	30K
05	1K	25	25K
06	1K	20	20K
07	1K	20	20K
08	1K	20	20K
09	1K	15	15K
10	1K	15	15K
11	1K	10	10K
12	1K	10	10K

纸箱规格:465\*315\*426MM

注意事项:

1. 产品不可少数、多数;
2. 内外包装均需有数量标签;
3. 不同PIN位包装时须分开放置不可装入同一外箱中。
4. 同一订单尾数包装需用不影响品质之物品填充并注明尾数。

REV.	REVISION RECORD	DATE		GENERAL TOLERANCES		SCALE: 1:1	NAME	DATE	PART.NO: C3030HF-1XXXX	DWG.NO: ENDE05	 WanLian Technology Co., Ltd	
AO	NEW RELEASE	21.10.12		LINEAR	ANGLES	APPROVED	Wang_jr	21.10.12				
			UNIT:mm	0.00±0.25	X'±3'	DESIGNER	Han_Gao	21.10.12	TITLE: Pitch3.00mm 180°单排带扣带翅膀母胶壳	REV: A0		SHEET: 2/2
			SIZE: A4	0.000±0.10	X'X' ±2'	DRAWN	Zijun_Huang	21.10.12				