

The product using material and processing must conform to the "WI-PZ-001"HSF technical standard control requirements

RoHS

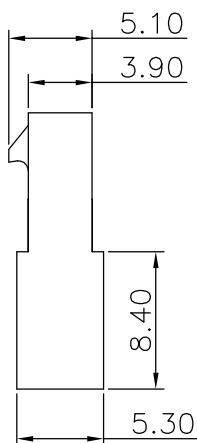
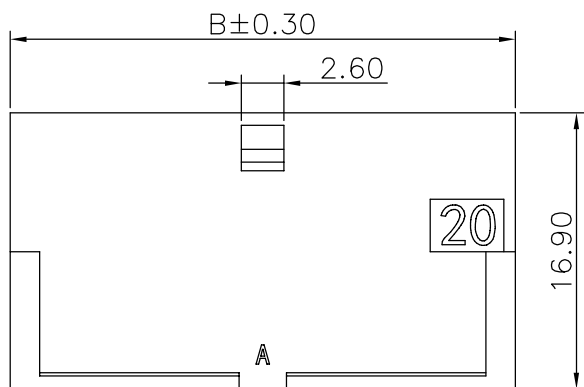
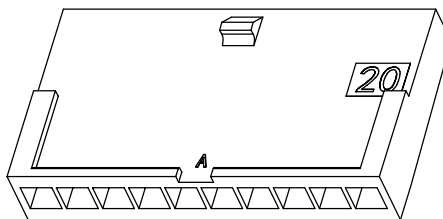
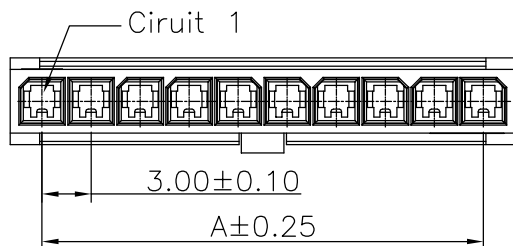

NOTE:

- 1.MATERIAL SPECIFICATION:
1-1.HOUSING: PA66,
- 2.ELECTRICAL PERFORMANCE:
2-1.INSULATION RESISTANCE: 1000MΩ Min
2-2.DIELECTRIC WITHSTANDING : 1000V
- 3.ENVIRONMENTAL PERFORMANCE:
3-1.OPERATING TEMPERATURE: -25°C~+85°C.
- 4.PACKAGE SPEC: PE BAG
- 5.P/N:

C3030 H 1 F-1 XX X X

SERIES NO: _____ HOUSING:
1-UL94V-0
2-UL94V-2

CONNECTOR: _____ H-HOUSING

1-TYPE CODE _____ COLOR:
A-BLACK
S-NATURE

MALE FEMALE: _____ F-FEMALE

ROW NO: _____ PIN Q' PY:
1-SINGLE ROW 02~12

Ordering Information & Dimensions

Circuit	Dimensions (mm)		Circuit	Dimensions (mm)	
	A	B		A	B
02	3.00	6.95	08	21.00	24.95
03	6.00	9.95	09	24.00	27.95
04	9.00	12.95	10	27.00	30.95
05	12.00	15.95	11	30.00	33.95
06	15.00	18.95	12	33.00	36.95
07	18.00	21.95			

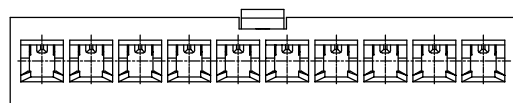

REV.	REVISION RECORD	DATE	UNIT:mm	GENERAL TOLERANCES		SCALE: 1:1	NAME	DATE	PART.NO:	DWG.NO:	 WanLian Technology Co., Ltd
AO	NEW RELEASE	21.11.17		SIZE: A4	LINEAR 0.00±0.25	ANGLES X°±3'	APPROVED	Wang_jr	21.11.17	C3030H1F-1XXXX	
				0.00±0.10	X°X' ±2'	DESIGNER	Han_Gao	21.11.17	TITLE: Pitch3.00mm 180°单排带扣不带翅螺母胶壳无LOGO		REV: A0
						DRAWN	Zijun_Huang	21.11.17			SHEET: 1/3

The product using material and processing must conform to the "WI-PZ-001"HSF technical standard control requirements

RoHS

孔位图

6PIN

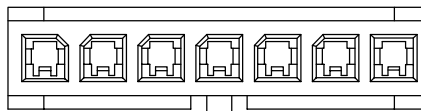
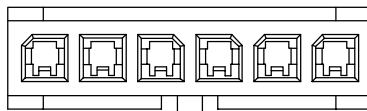

7PIN

8PIN

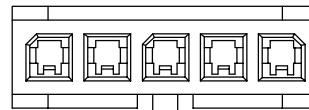
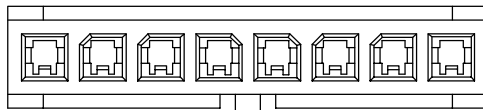

5PIN

9PIN

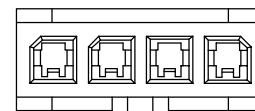
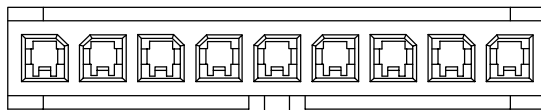

4PIN

10PIN

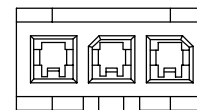
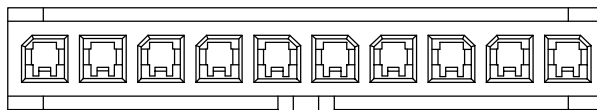

3PIN

11PIN

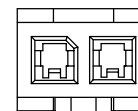
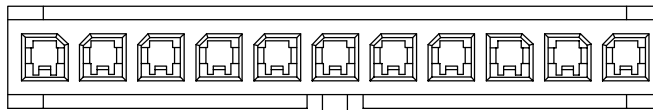

2PIN

12PIN

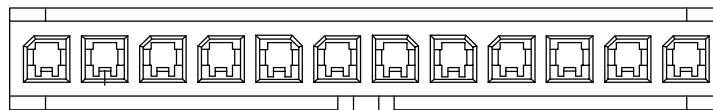

REV.	REVISION RECORD	DATE		GENERAL TOLERANCES		SCALE: 1:1	NAME	DATE	PART.NO: C3030H1F-1XXXX	DWG.NO: ENDE05	 WanLian Technology Co., Ltd
A0	NEW RELEASE	21.11.17		LINEAR	ANGLES	APPROVED	Wang_jr	21.11.17			
			UNIT:mm	0.00±0.25	X'±3°	DESIGNER	Han_Gao	21.11.17	TITLE: Pitch3.00mm 180°单排带扣不带翅膀母胶壳无LOGO		REV: A0 SHEET: 2/3
			SIZE: A4	0.000±0.10	X'X' ±2°	DRAWN	Zijun_Huang	21.11.17			

The product using material and processing must conform to the "WI-PZ-001"HSF technical standard control requirements

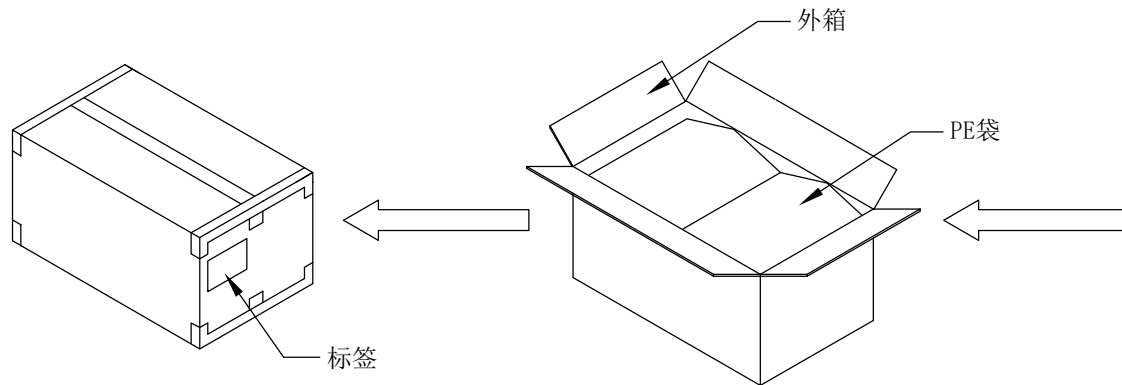
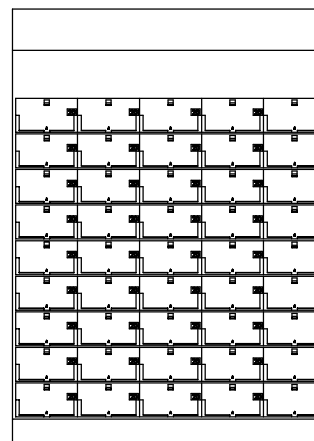
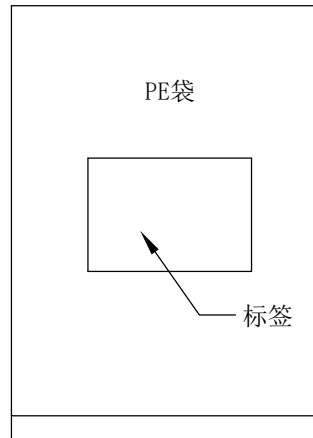
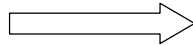
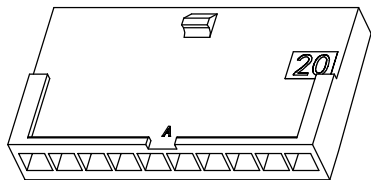

纸箱规格: 465*315*426MM

Circuit	Bag Pcs	CARTON Bag	CARTON Pcs
02	1K	30	30K
03	1K	30	30K
04	1K	30	30K
05	1K	25	25K
06	1K	20	20K
07	1K	20	20K
08	1K	20	20K
09	1K	15	15K
10	1K	15	15K
11	1K	10	10K
12	1K	10	10K

注意事项:

1. 产品不可少数、多数;
2. 内外包装均需有数量标签;
3. 不同PIN位包装时须分开放置不可装入同一外箱中。
4. 同一订单尾数包装需用不影响品质之物品填充并注明尾数。

REV.	REVISION RECORD	DATE		GENERAL TOLERANCES		SCALE: 1:1	NAME	DATE	PART.NO: C3030H1F-1XXXX	DWG.NO: ENDE05	 WanLian Technology Co., Ltd
AO	NEW RELEASE	21.11.17		LINEAR	ANGLES	APPROVED	Wang_jr	21.11.17			
			UNIT:mm	0.00±0.25	X'±3'	DESIGNER	Han_Gao	21.11.17	TITLE: PACKAGE SPEC	REV: A0	
			SIZE: A4	0.000±0.10	X'X' ±2'	DRAWN	Zijun_Huang	21.11.17			