

The product using material and processing must conform to the "WI-PZ-001"HSF technical standard control requirements

RoHS

- NOTE:
- MATERIAL SPECIFICATION:
 - HOUSING: LCP,UL94V-0
 - CONTACTS: BRASS
 - PLATING SPECIFICATION:
 - CONTACTS: TIN PLATED
 - ELECTRICAL PERFORMANCE:
 - CURRENT RATING: 7A
 - CONTACT RESISTANCE: 20 mΩ MAX
 - INSULATION RESISTANCE: 1000MΩ Min
 - DIELECTRIC WITHSTANDING : 1500V
 - ENVIRONMENTAL PERFORMANCE:
 - OPERATING TEMPERATURE: -25°C~+85°C.
 - PACKAGE SPEC: REEL
 - P/N:

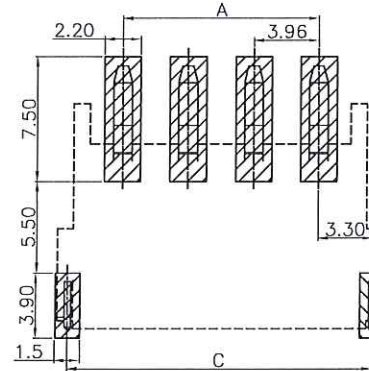
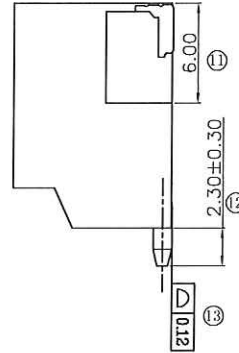
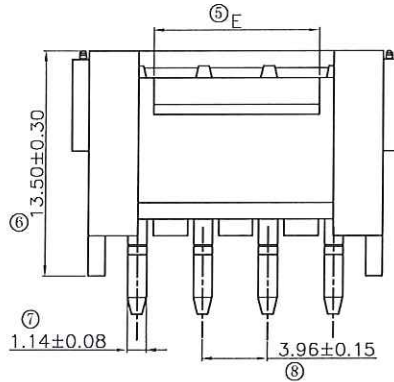
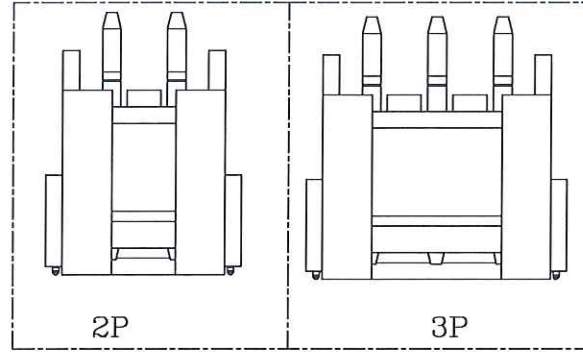
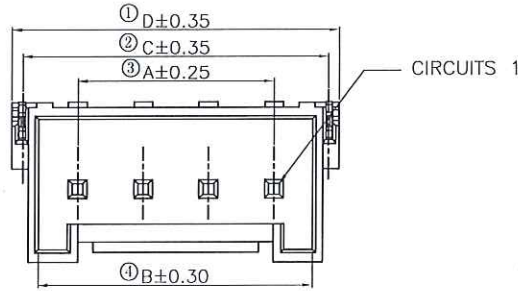

RECOMMENDED PCB LAYOUT
(GENERAL TOLERANCE:±0.05)

Δ 1 A3962 W 9-1 XX 2 X X X
 SERIES NO: WATER CODE 0-N/A
 CONNECTOR: W-WAFER COLOR: A-BLACK S-NATURE
 ANGLE: 9-90~ 0-180~
 ROW NO: 1-SINGLE ROW PLATING: C-BRIGHT TIN
 PIN Q'PY: 02~16 TERMIPOINT: 2-SMT

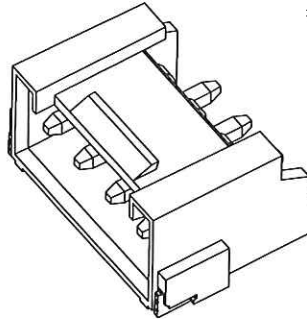
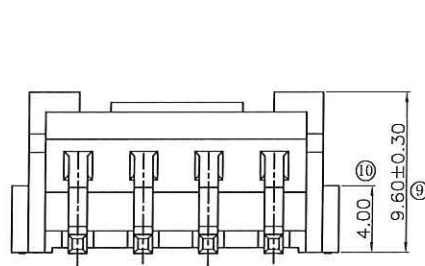

Circuits	Dimensions (mm)				
	A	B	C	D	E
02	3.96	8.68	10.61	11.88	3.88
03	7.92	12.64	14.57	15.84	7.84
04	11.88	16.6	18.53	19.8	
05	15.84	20.56	22.49	23.76	
06	19.8	24.52	26.45	27.72	
07	23.76	28.48	30.41	31.68	
08	27.72	32.44	34.37	35.64	
09	31.68	36.4	38.33	39.6	
10	35.64	40.36	42.29	43.56	10.00
11	39.6	44.32	46.25	47.52	
12	43.56	48.28	50.21	51.48	
13	47.52	52.24	54.17	55.44	
14	51.48	56.2	58.13	59.4	
15	55.44	60.16	62.09	63.36	
16	59.4	64.12	66.05	67.32	

REV.	REVISION RECORD	DATE	GENERAL TOLERANCES	SCALE:	NAME	DATE	PART.NO:	DWG.NO:
A0	NEW RELEASE	21.10.15	LINEAR	1:1			A3962W9-1XX2XXX	ENDE05
A1	PART NUMBER RENEWAL		ANGLES	APPROVED	梁林积	2024.6.5		
			0.0±0.35	DESIGNER	梁林积	2024.6.5	TITLE:	
			0.00±0.25	DRAWN	梁雨曠	2024.6.5	Pitch 3.96mm 90° 单排卧贴 Wafer	REV: A1
			0.000±0.10					SHEET: 1/2



The product using material and processing must conform to the "WI-PZ-001"HSF technical standard control requirements



NOTE(注):

1. 10 SPROCKET HOLE PITCH CUMULATIVE TOLERANCE $\pm 0.2\text{mm}$. (10片孔距累积公差 $\pm 0.2\text{mm}$.)
2. CARRIER CAMBER NOT TO EXCEED 1mm IN 100mm. (载带拱/弧形MAX: 1/100mm.)
3. ALL DIMENSIONS MEET EIA-481 REQUIREMENTS. (所有的尺寸要满足协会EIA-481规范.)
4. MATERIAL: CLEAR ANTISTATIC PS. (载带材料: 透明防静电 PS.)
5. THICKNESS: $0.50 \pm 0.05\text{mm}$. (载带厚度: $0.50 \pm 0.05\text{mm}$.)
6. PACKING LENGTH PER REEL: 7.68 METERS. (每卷包装长度: 7.68米.)
7. COMPONENT LOAD PER REEL: 300 PCS. (每卷包装数量: 300只.)
8. Carton packing to no more than the line, using the free slots filled with plastic foam and nylon. (纸箱装箱以不超过装箱线为准, 空余位置用塑料泡沫及保尼龙填充.)
9. 纸箱分小、中、标准型3种规格型号: 装箱为整箱(左下包装量)采用标准型纸箱包装, 未达到整箱数量以产品量适当采用小型或中型纸箱包装.

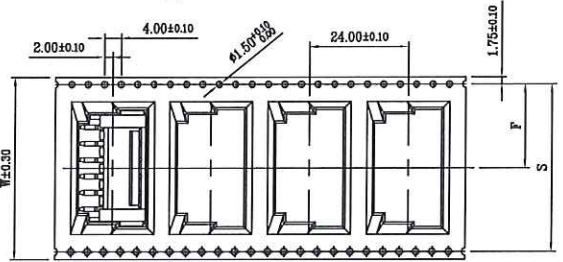
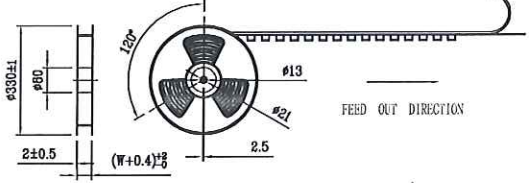
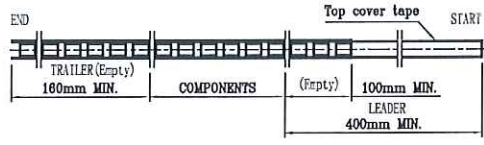

Circuits	W	PCS/REEL	REEL/CARTON	SUM(PCS)
02	24	300	10	3000
03	32	300	8	2400
04	44	300	6	1800
05		300	6	1800
06		300	6	1800
07	56	300	4	1200
08		300	4	1200
09		300	4	1200
10	72	300	3	900
11		300	3	900
12		300	3	900
13		300	3	900
14	88	300	3	900
15		300	3	900
16		300	3	900

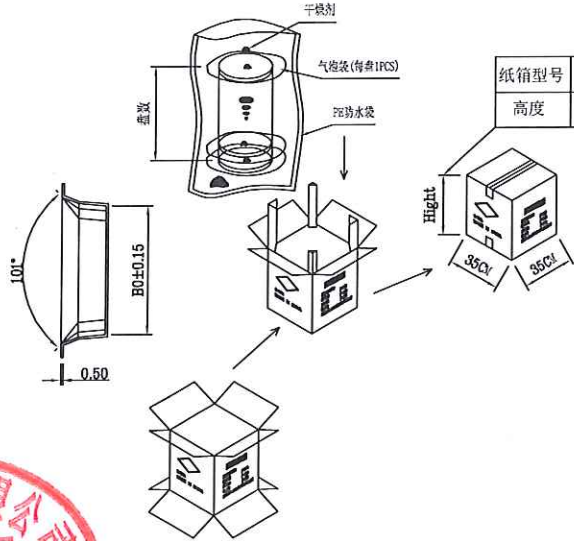

纸箱型号	小型	中型	标准型
高度	7.5	15	32

Circuits	B0	W	F	S
02	12.38	24	11.50	/
03	16.34	32	14.20	28.40
04	20.30	44	20.20	40.40
05	24.26			
06	28.22			
07	32.18	56	26.20	52.40
08	36.14			
09	40.1			
10	44.06	72	34.20	68.40
11	48.02			
12	51.98			
13	55.94			
14	59.90	88	42.20	84.40
15	63.86			
16	67.82			



REV.	REVISION RECORD	DATE	GENERAL TOLERANCES	SCALE: 1:1	NAME	DATE	PART.NO:	DWG.NO:
A0	NEW RELEASE	21.10.15	LINEAR	APPROVED	梁林积	2024.6.5	A3962W9-1XX2XXX	ENDE05
A1	PART NUMBER RENEWAL		0.0±0.35	DESIGNER	梁林积	2024.6.5	TITLE:	WanLian Technology Co., Ltd
			0.00±0.25	DRAWN	肖雨曦	2024.6.5	Pitch 3.96mm 90° 单排卧贴 Wafer	
			0.000±0.10					



REV: A1 SHEET: 2/2