

The product using material and processing must conform to the "WI-PZ-001"HSF technical standard control requirements

ROHS+HF

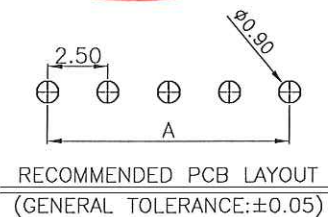
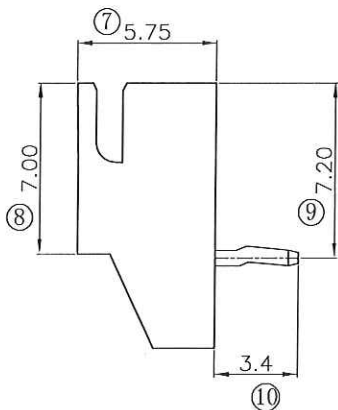
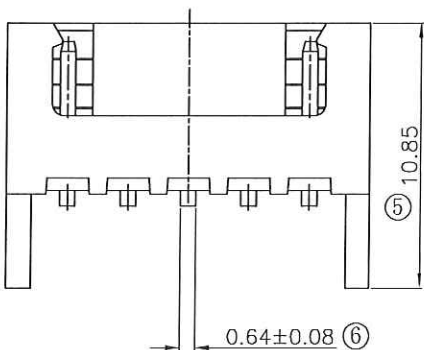
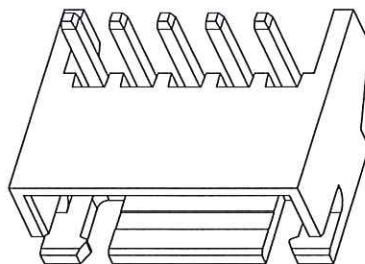
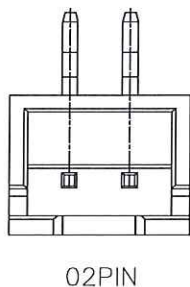
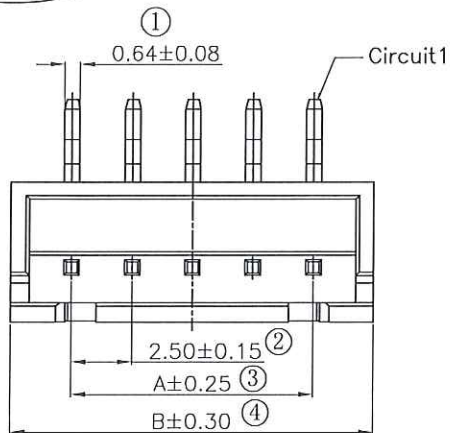

NOTE:
 1.MATERIAL SPECIFICATION:
 1-1.HOUSING: PA66,UL94V-0
 1-2.CONTACTS: BRASS
 2.PLATING SPECIFICATION:
 2-1.CONTACTS:
 TIN/GOLD FLASH PLATED OVER ALL.
 3.ELECTRICAL PERFORMANCE:
 3-1.CURRENT RATING: 3.0A
 3-2.CONTACT RESISTANCE: 20mΩ Max.
 3-3.INSULATION RESISTANCE: 1000MΩ MIN
 3-4.DIELECTRIC WITHSTANDING: 1000V AC Min
 4.ENVIRONMENTAL PERFORMANCE:
 OPERATING TEMPERATURE: -25°C~+85°C.
 5.PACKAGE SPEC: PE BAG
 6.P/N ORDER:

SERIES NO: A2501 W 9 5-1 XX 1 X X X
 CONNECTOR: W-WAFER
 ANGLE: 9-90°
 TYPE: 5-TYPE 5
 ROW NO: 1-SINGLE ROW
 PIN Q'PY: 02~16
 CHARACTERISTIC: 1-PLAY K
 COLOR: A-BLACK K-WHITE
 PLATING: A-ALL AU G/F C-BRIGHE TIN D-MATTE Tin
 TERMIPOINT: 1-DIP

Circuits	Dimensions(mm)		Circuits	Dimensions(mm)	
	A	B		A	B
02	2.50	7.50	10	22.50	27.50
03	5.00	10.00	11	25.00	30.00
04	7.50	12.50	12	27.50	32.50
05	10.00	15.00	13	30.00	35.00
06	12.50	17.50	14	32.50	37.50
07	15.00	20.00	15	35.00	40.00
08	17.50	22.50	16	37.50	42.50
09	20.00	25.00			



REV.	REVISION RECORD	DATE	GENERAL TOLERANCES		SCALE:	NAME	DATE	PART.NO:	DWG.NO:	WanLian Technology Co., Ltd
A0	NEW RELEASE		LINEAR	ANGLES	1:1	梁林积	2024.5.28	A2501W95-1XX1XXX	ENDE05	
			0.0±0.35	X'REF±6'	APPROVED	肖雨羲	2024.5.28			
			UNIT:mm	0.00±0.25	DESIGNER			TITLE:		
			SIZE: A4	0.000±0.10	DRAWN			Pitch 2.50mm 90°XH WAFER 带定位 打K	REV: A0	SHEET: 1/2

The product using material and processing must conform to the "WI-PZ-001"HSF technical standard control requirements

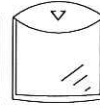
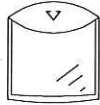
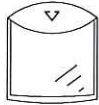
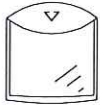
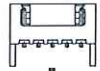

PE袋 1 Pcs

数量 :每袋=0.4~2Kpcs

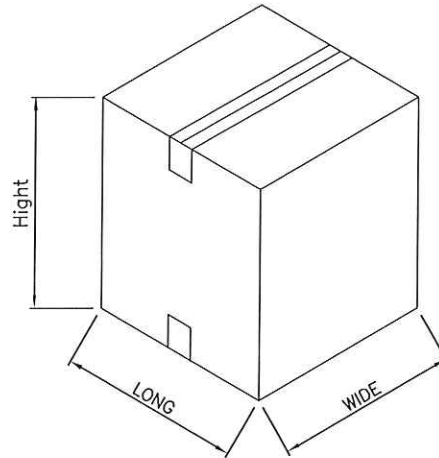
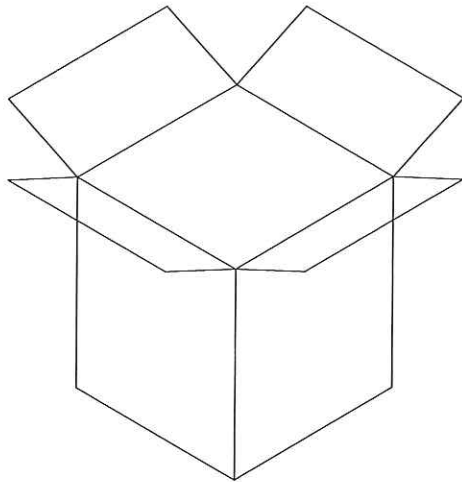

NOTE(注):

1. 纸箱装箱以不超过装箱线为准,空余位置用塑料泡沫及保尼龙填充;
2. 纸箱分小、中、标准型、大4种规格型号; 装箱为整箱(左下包装量)采用大型纸箱包装,未达到整箱数量以产品量适当采用小型、中型或标准型纸箱包装;
3. 因生产Pin位未齐全,每袋与整箱包装数量仅供参考,具体包装数量以实际出货为准,或批量出货更新后为准;



纸箱型号 Carton Type	小型 Small Size	中型 Medium	标准型 Standard	大型 Large
长度 Long (CM)	35	35	35	46
宽度 Wide (CM)	35	35	35	46
高度 Height (CM)	7.5	15	32	46

袋装包装数量

CKT	PCS/BAG
2	2000
3	2000
4	2000
5	1000
6	1000
7	1000
8	1000
9	500
10	500
11	500
12	500
13	500
14	500
15	400
16	400

REV.	REVISION RECORD	DATE		GENERAL TOLERANCES		SCALE: 1:1	NAME	DATE	PART.NO:	DWG.NO:	 WanLian Technology Co., Ltd
AO	NEW RELEASE			LINEAR	ANGLES	APPROVED	梁林秋	2024.5.28	A2501W95-1XX1XXX	ENDE05	
				0.0±0.35	X°REF±6'	DESIGNER	梁林秋	2024.5.28	TITLE:		
				UNIT:mm	0.00±0.25	X'±3'	DRAWN	肖雨曦	2024.5.28	Pitch 2.50mm 90°XH WAFER 带定位 打K	
			SIZE: A4	0.000±0.10	X'X' ±2'						