

The product using material and processing must conform to the "WI-PZ-001"HSF technical standard control requirements

ROHS+HF

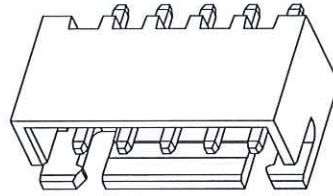

- NOTE:
- MATERIAL SPECIFICATION:
 - HOUSING: PA66,UL94V-0
 - CONTACTS: BRASS
 - PLATING SPECIFICATION:
 - CONTACTS: SN PLATED OVER ALL.
 - ELECTRICAL PERFORMANCE:
 - CURRENT RATING: 3.0A
 - CONTACT RESISTANCE: 20mΩ Max.
 - INSULATION RESISTANCE: 1000MΩ MIN
 - DIELECTRIC WITHSTANDING: 1000V AC Min
 - ENVIRONMENTAL PERFORMANCE:
 - OPERATING TEMPERATURE: -25°C~+85°C.
 - PACKAGE SPEC: PE BAG
 - P/N ORDER:

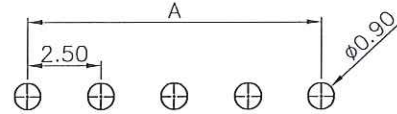
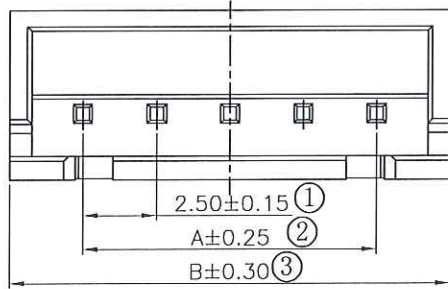

RECOMMENDED PCB LAYOUT
(GENERAL TOLERANCE: ±0.05)

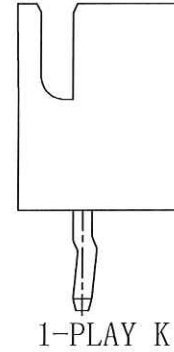

Series No: A1 A2501 W 0-1 XX 1 X X X

CONNECTOR: W-WAFER

ANGLE: 0-180

ROW NO: 1-SINGLE ROW

PIN Q'PY: 02~16

CHARACTERISTIC: 1-PLAY K, 2-NO K

COLOR: A-BLACK, K-WHITE

PLATING: A-ALL AU G/F, C-BRIGHE TIN, D-MATTE Tin

TERMIPOINT: 1-DIP

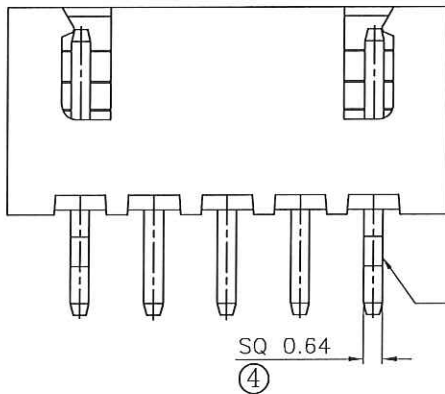

Circuit 1

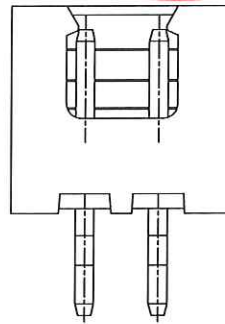

2PIN

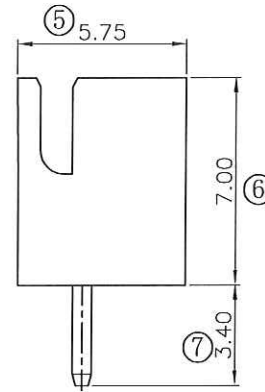

2-NO K

Circuits	Dimensions(mm)		Circuits	Dimensions(mm)	
	A	B		A	B
02	2.50	7.50	10	22.50	27.50
03	5.00	10.00	11	25.00	30.00
04	7.50	12.50	12	27.50	32.50
05	10.00	15.00	13	30.00	35.00
06	12.50	17.50	14	32.50	37.50
07	15.00	20.00	15	35.00	40.00
08	17.50	22.50	16	37.50	42.50
09	20.00	25.00			

REV.	REVISION RECORD	DATE	GENERAL TOLERANCES	SCALE: 1:1	NAME	DATE	PART.NO:	DWG.NO:
A0	NEW RELEASE	21.01.13	LINEAR	APPROVED	梁林积	2024.5.28	A2501W0-1XX1XXX	ENDE05
A1	PART NUMBER RENEWAL		0.0±0.35	DESIGNER	梁林积	2024.5.28	TITLE: Pitch 2.50mm 180° XII WAFER	REV: A1 SHEET: 1/2
			0.000±0.10	DRAWN	肖雨曦	2024.5.28		



1

2

3

4

5

6

7

8

The product using material and processing must conform to the "WI-PZ-001"HSF technical standard control requirements

ROHS+HF

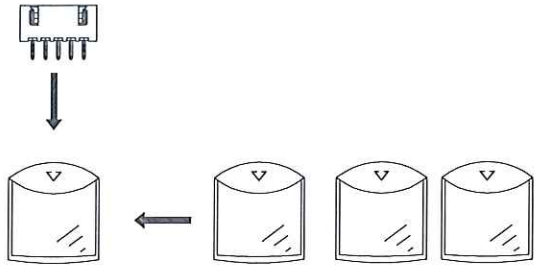

PE袋 1 Pcs

数量 :每袋=0.4~2Kpcs

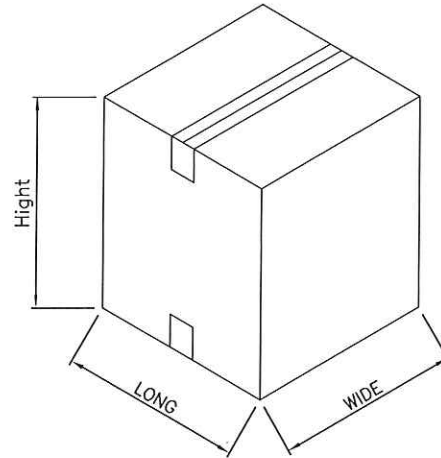
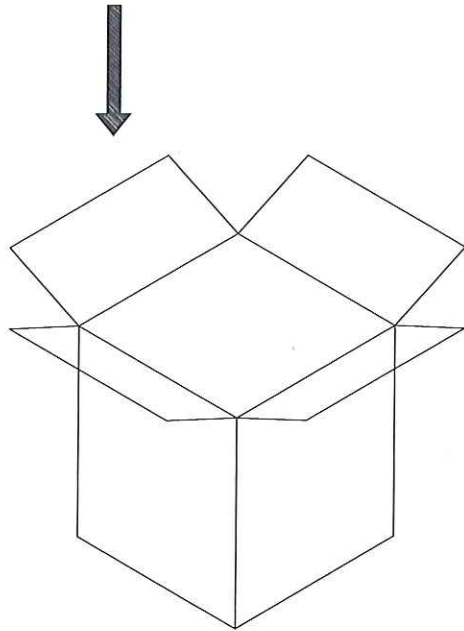

NOTE(注):

1. 纸箱装箱以不超过装箱线为准,空余位置用塑料泡沫及保尼龙填充;
2. 纸箱分小、中、标准型、大4种规格型号; 装箱为整箱(左下包装量)采用大型纸箱包装, 未达到整箱数量以产品量适当采用小型、中型或标准型纸箱包装;
3. 因生产Pin位未齐全, 每袋与整箱包装数量仅供参考, 具体包装数量以实际出货为准, 或批量出货更新后为准;



纸箱型号 Carton Type	小型 Small Size	中型 Medium	标准型 Standard	大型 Large
长度 Long (CM)	35	35	35	46
宽度 Wide (CM)	35	35	35	46
高度 Height (CM)	7.5	15	32	46

袋装包装数量

CKT	PCS/BAG
2	2000
3	2000
4	2000
5	1000
6	1000
7	1000
8	1000
9	500
10	500
11	500
12	500
13	500
14	500
15	400
16	400

REV.	REVISION RECORD	DATE		GENERAL TOLERANCES		SCALE: 1:1	NAME	DATE	PART.NO:	DWG.NO:	
A0	NEW RELEASE	21.01.13			LINEAR	ANGLES	APPROVED	梁林秋	2024.5.28	A2501W0-1XX1XXX	
A1	PART NUMBER RENEWAL			0.0±0.35	X'REF±6'	DESIGNER	梁林秋	2024.5.28	TITLE:		REV: A1 SHEET: 2/2
			UNIT:mm	0.00±0.25	X'±3'	DRAWN	肖雨曦	2024.5.28	Pitch 2.50mm 180°XH WAFER		