

The product using material and processing must conform to the "WI-PZ-001"HSF technical standard control requirements

RoHS

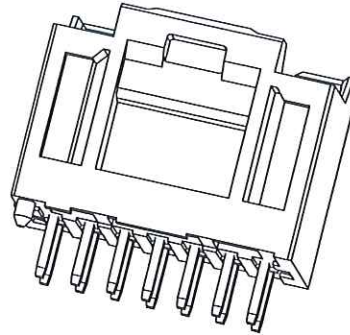

- NOTE:
- MATERIAL SPECIFICATION:
    - HOUSING: LCP,UL94V-0
    - CONTACTS: BRASS
  - PLATING SPECIFICATION:
    - CONTACTS: TIN/GOLD FLASH PLATED OVER ALL.
  - ELECTRICAL PERFORMANCE:
    - CURRENT RATING: 2A
    - CONTACT RESISTANCE: 20 mΩ MAX
    - INSULATION RESISTANCE: 1000MΩ Min
    - DIELECTRIC WITHSTANDING : 1000V
  - ENVIRONMENTAL PERFORMANCE:
    - OPERATING TEMPERATURE: -40°C~+105°C.
  - PACKAGE SPEC: TRAY
  - P/N:

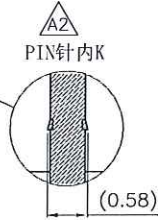
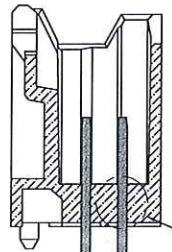
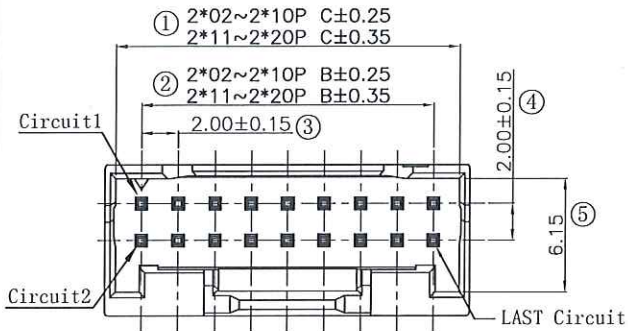
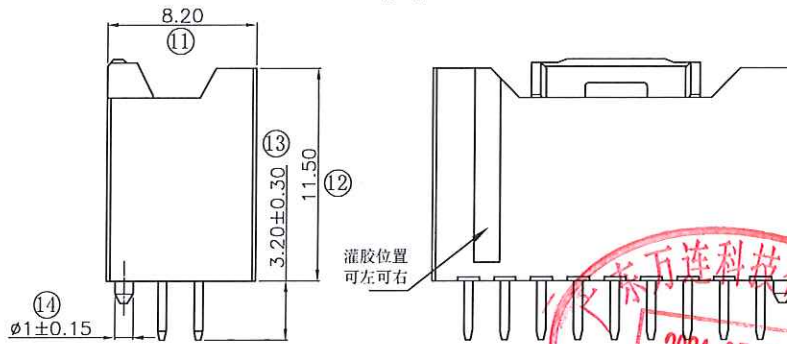
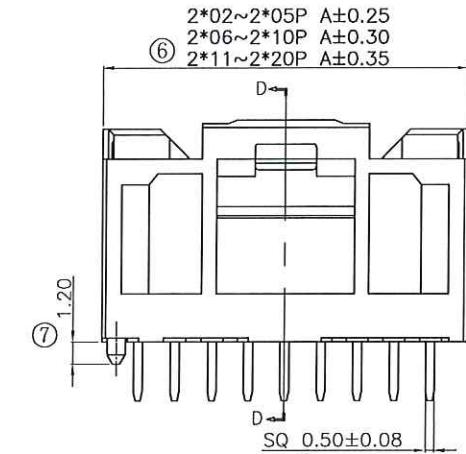

A1 A2036 W 0-2 XX 1 X X 0

SERIES NO: \_\_\_\_\_

MALE FEMALE: \_\_\_\_\_  
F-FEMALE

ANGLE: \_\_\_\_\_  
9-90°  
0-180°

ROW NO: \_\_\_\_\_  
2-DOUBLE ROW

PIN Q'PY: \_\_\_\_\_  
04~40

COLOR:  
A-BLACK  
S-NATURE

PLATING:  
A-ALL AU G/F  
C-BRIGHT TIN  
D-MATTE TIN

TERMIPOINT:  
1-DIP

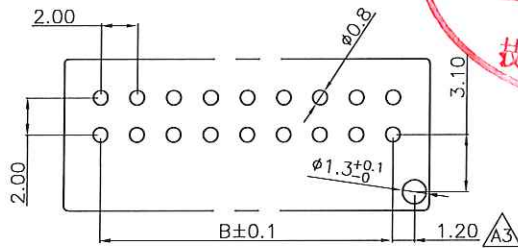
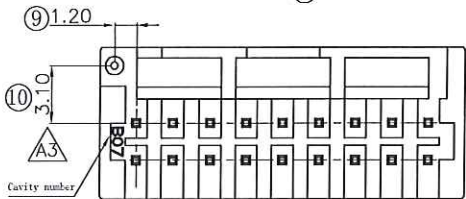

RECOMMENDED PCB LAYOUT  
(GENERAL TOLERANCE:±0.05)

Circuit	Dimensions(mm)			Circuit	Dimensions(mm)		
	A	B	C		A	B	C
2*02	6	2	4.8	2*12	26	22	24.8
2*03	8	4	6.8	2*13	28	24	26.8
2*04	10	6	8.8	2*14	30	26	28.8
2*05	12	8	10.8	2*15	32	28	30.8
2*06	14	10	12.8	2*16	34	30	32.8
2*07	16	12	14.8	2*17	36	32	34.8
2*08	18	14	16.8	2*18	38	34	36.8
2*09	20	16	18.8	2*19	40	36	38.8
2*10	22	18	20.8	2*20	42	38	40.8
2*11	24	20	22.8				



REV.	REVISION RECORD	DATE	GENERAL TOLERANCES	SCALE: 1:1	NAME	DATE	PART.NO:	DWG.NO:	 WanLian Technology Co., Ltd
A0	NEW RELEASE	21.10.12	LINEAR	APPROVED	梁林积	2024.5.30	A2036W0-2XX1XX0	ENDE05	
A1	PART NUMBER RENEWAL	23.09.22	0.0±0.35	DESIGNER	梁林积	2024.5.30	TITLE: Pitch2.00mm MX180° 双排带柱带扣立插无logo Wafer	REV: A3	
A2	ADD PIN INSIDE K	23.12.07	0.00±0.25	DRAWN	梁雨曦	2024.5.30			
A3	MODIFIED IN KIND ON BASIS		0.000±0.10						
			ANGLES X'REF±6°					SHEET: 1/4	

The product using material and processing must conform to the "WI-PZ-001"HSF technical standard control requirements

RoHS

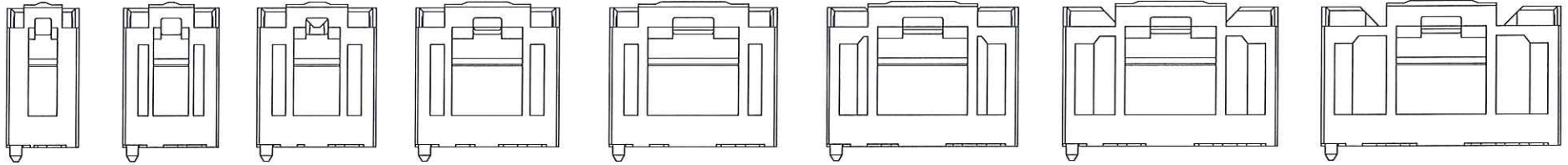
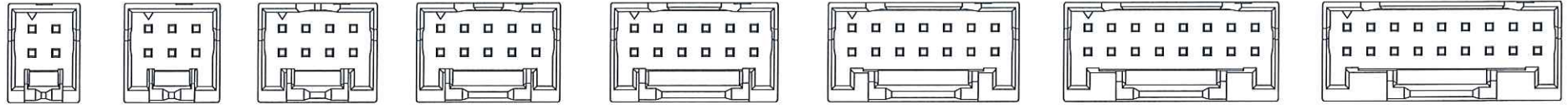

2\*02P    2\*03P    2\*04P    2\*05P    2\*06P    2\*07P    2\*08P    2\*09P

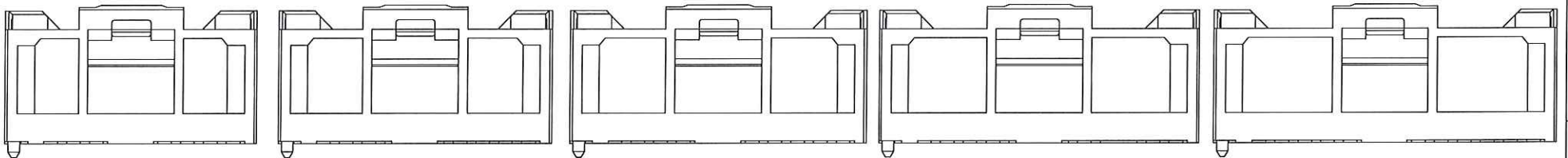
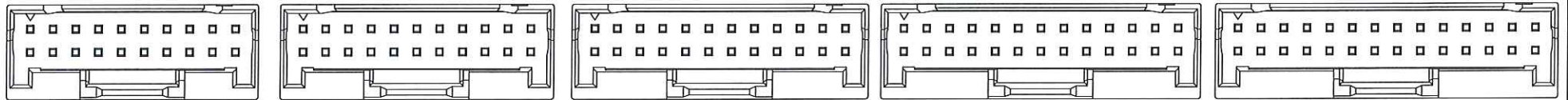

2\*10P    2\*11P    2\*12P    2\*13P    2\*14P

REV.	REVISION RECORD	DATE		GENERAL TOLERANCES		SCALE: 1:1	NAME	DATE	PART.NO:	DWG.NO:	 WanLian Technology Co., Ltd
A0	NEW RELEASE	21.10.12		LINEAR	ANGLES	APPROVED			A2036W0-2XX1XX0	ENDE05	
A1	PART NUMBER RENEWAL	23.09.22		0.0±0.35	X'REF±6°	DESIGNER			TITLE:		
A2	ADD PIN INSIDE K	23.12.07		UNIT: mm	0.00±0.25	X'±3'			Pitch2.00mm MX180° 双排带柱带扣立插无logo Wafer	REV: A3	SHEET: 2/4
A3	MODIFIED IN KIND ON BASIS			SIZE: A4	0.000±0.10	X'X' ±2'	DRAWN				

The product using material and processing must conform to the "WI-PZ-001"HSF technical standard control requirements

RoHS

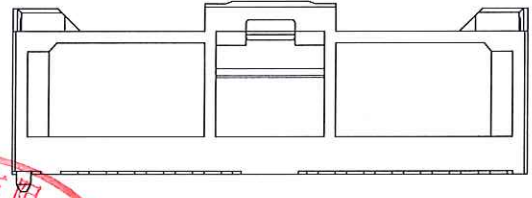
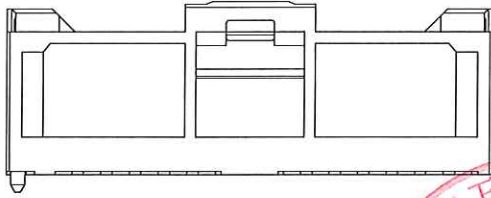
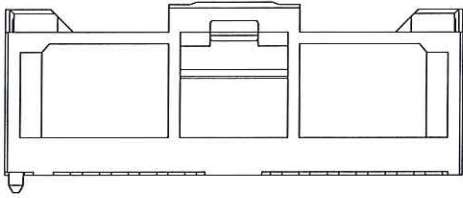
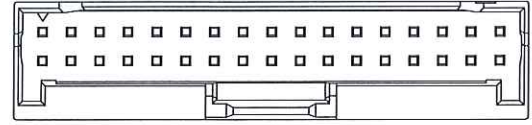
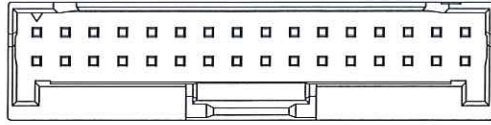
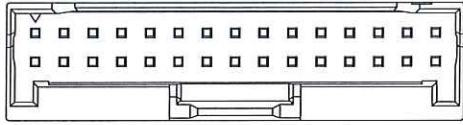

2\*15P

2\*16P

2\*17P

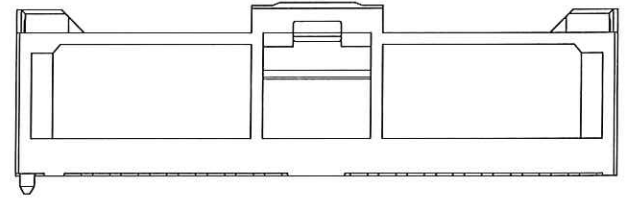
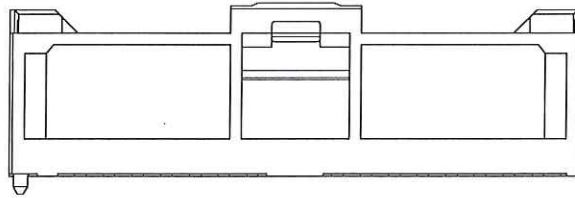
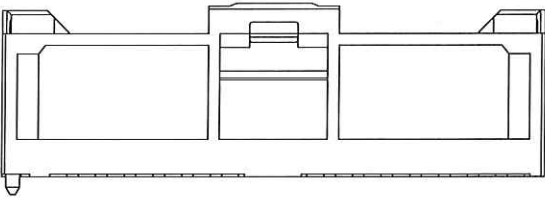
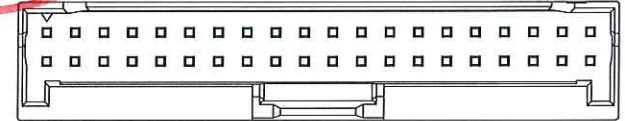
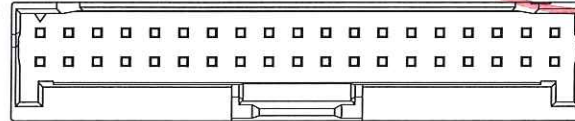
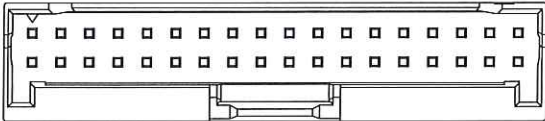

2\*18P

2\*19P

2\*20P



REV.	REVISION RECORD	DATE		GENERAL TOLERANCES		SCALE: 1:1	NAME	DATE	PART.NO: A2036W0-2XX1XX0	DWG.NO: ENDE05	 WanLian Technology Co., Ltd
A0	NEW RELEASE	21.10.12		LINEAR	ANGLES	APPROVED	梁林积	2024.5.30			
A1	PART NUMBER RENEWAL	23.09.22		0.0±0.35	X'REF±6°	DESIGNER	梁林积	2024.5.30	TITLE: Pitch2.00mm MX180° 双排带柱带扣立插无logo Wafer		
A2	ADD PIN INSIDE K	23.12.07		UNIT: mm	0.00±0.25	X'±3'	DRAWN	肖雨曦		2024.5.30	
A3	MODIFIED IN KIND ON BASIS			SIZE: A4	0.000±0.10	X'X' ±2'					
									REV: A3	SHEET: 3/4	

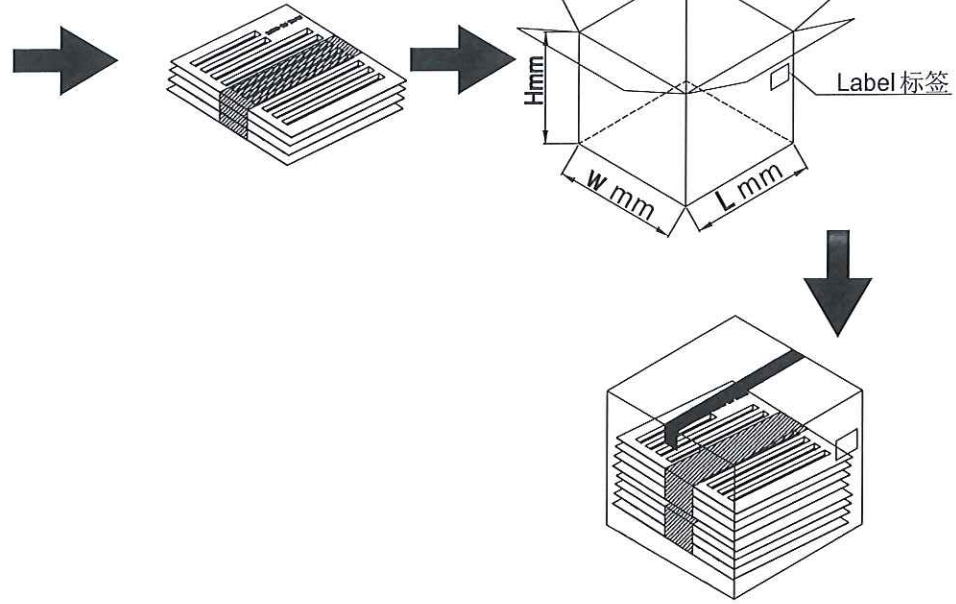
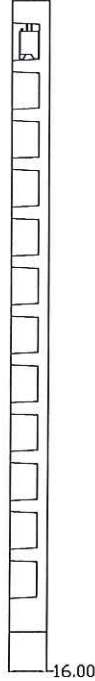

The product using material and processing must conform to the "WI-PZ-001"HSF technical standard control requirements

RoHS



POLES	包装数量/盘/PCS	POLES	包装数量/盘/PCS
2*02	446	2*12	102
2*03	332	2*13	92
2*04	264	2*14	80
2*05	218	2*15	80
2*06	184	2*16	80
2*07	160	2*17	68
2*08	148	2*18	68
2*09	126	2*19	58
2*10	114	2*20	58
2*11	104		



REV.	REVISION RECORD	DATE	GENERAL TOLERANCES		SCALE:	NAME	DATE	PART.NO:	DWG.NO:	 WanLian Technology Co., Ltd
A0	NEW RELEASE	21.10.12		LINEAR	1:1	3/8 陈	2024.5.30	A2036W0-2XX1XX0	ENDE05	
A1	PART NUMBER RENEWAL	23.09.22		0.0±0.35	ANGLES					
A2	ADD PIN INSIDE K	23.12.07	UNIT: mm	0.00±0.25	X'REF±6'	DESIGNER	梁林祯	TITLE:	REV: A3	
A3	MODIFIED IN KIND ON BASIS		SIZE: A4	0.000±0.10	X'X' ±2'	DRAWN	肖雨曦			Pitch2.00mm MX180° 双排带柱带扣立插无logo Wafer