

The product using material and processing must conform to the "WI-PZ-001" HSF technical standard control requirements



NOTE:

- MATERIAL SPECIFICATION:
  - 1-1.HOUSING: PA10T,UL94V-0  $\Delta$ A1
  - 1-2.CONTACTS: BRASS
- PLATING SPECIFICATION:
  - 2-1.CONTACTS: TIN/GOLD FLASH PLATED OVER ALL.
- ELECTRICAL PERFORMANCE:
  - 3-1.CURRENT RATING: 3A AC/DC
  - 3-2.CONTACT RESISTANCE: 20 m $\Omega$  MAX
  - 3-3.INSULATION RESISTANCE: 1000M $\Omega$  Min
  - 3-4.DIELECTRIC WITHSTANDING : 1000V
- ENVIRONMENTAL PERFORMANCE:
  - 4-1.OPERATING TEMPERATURE: -25°C~+85°C.
- PACKAGE SPEC: PE BAG
- P/N/N:

SERIES NO: A2009 W 9 2-2 XX 1 X X X  
 CONNECTOR: W-WAFER  
 ANGLE: 9-90°  
 TYPE: 2-TYPE 2  
 ROW NO: 2-DOUBLE ROW  
 PIN Q'PY: 04~30

WATER CODE: 0-N/A  
 COLOR: M-BEIGE  
 PLATING: C-BRIGHT TIN  
 TERMIPOINT: 1-DIP

Circuit	Dimensions(mm)			Circuit	Dimensions(mm)		
	A	B	C		A	B	C
2*02	---	6.00	3.20	2*09	16.00	20.00	13.00
2*03	4.00	8.00	3.20	2*10	18.00	22.00	15.00
2*04	6.00	10.00	3.00	2*11	20.00	24.00	17.00
2*05	8.00	12.00	5.00	2*12	22.00	26.00	19.00
2*06	10.00	14.00	7.00	2*13	24.00	28.00	21.00
2*07	12.00	16.00	9.00	2*14	26.00	30.00	23.00
2*08	14.00	18.00	11.00	2*15	28.00	32.00	25.00

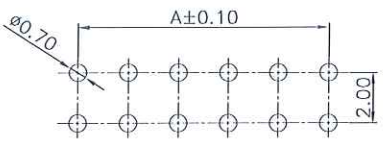
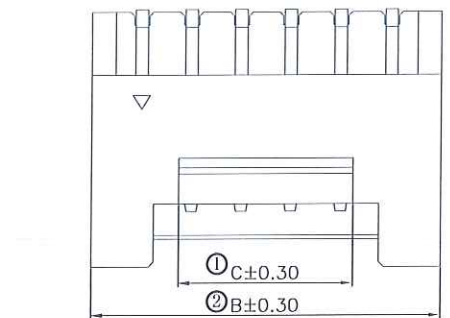

RECOMMENDED PCB LAYOUT  
 (GENERAL TOLERANCE:±0.05)

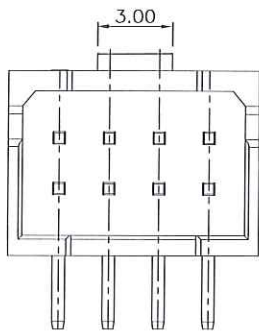
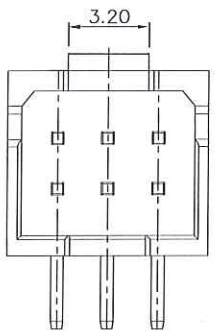
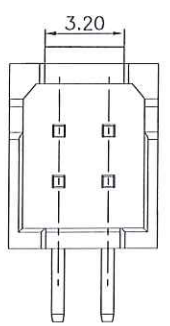
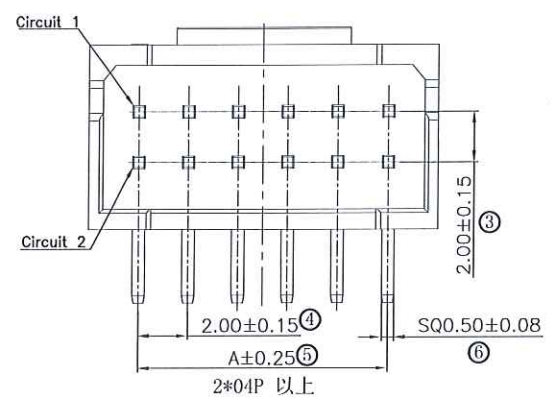
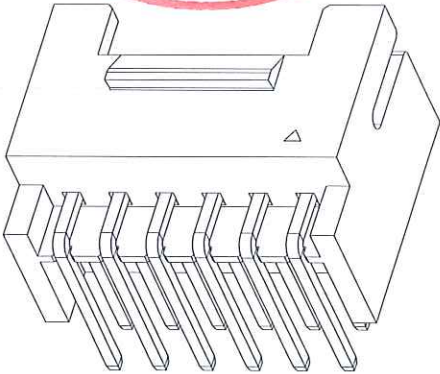
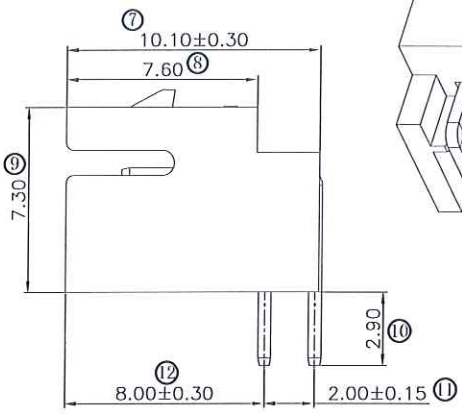

REV.	REVISION RECORD	DATE		GENERAL TOLERANCES		SCALE: 1:1	NAME	DATE	PART.NO:	DWG.NO:	 WanLian Technology Co., Ltd
A0	NEW RELEASE	22.03.19		LINEAR	ANGLES	APPROVED	张洪	25.2.19	A2009W92-2XX1XXX	ENDE05	
A1	PA6T IS CHANGED TO PA10T	25.02.19		0.0±0.35	X'REF±6°	CHECK	李洪	25.2.19	TITLE: Pitch 2.0mm 90° 双排 DIP Wafer	REV: A1	
				0.00±0.25	X'±3°	DRAWN	黄登楠	25.2.19			
			UNIT:mm	0.00±0.25							
			SIZE: A4	0.000±0.10	X'X' ±2°						

The product using material and processing must conform to the "WI-PZ-001" HSF technical standard control requirements

RoHS

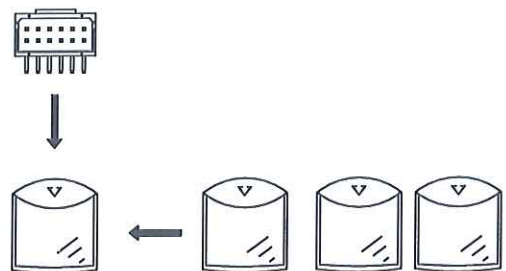

PE袋 1 Pcs  
数量 :每袋=2~0.3Kpcs

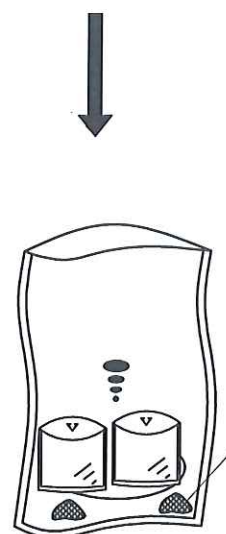

PE防水袋 1 Pcs

干燥剂

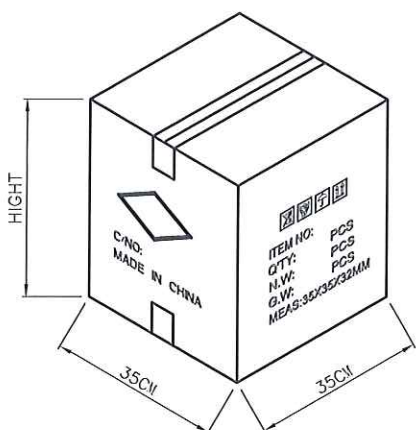
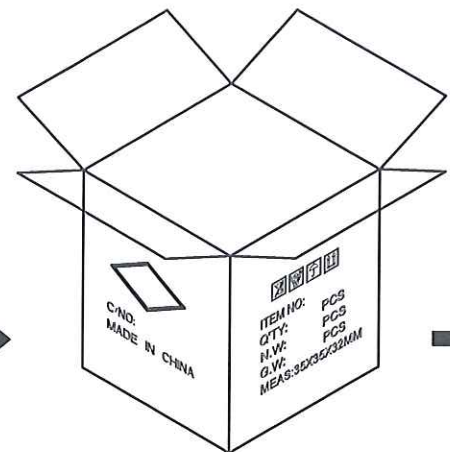

备注:

1. 纸箱装箱以不超过装箱线为准, 空余位置用塑料泡沫及保尼龙填充;
2. 纸箱分小、中、标准型3种规格型号: 装箱为整箱(左下包装量)采用标准型纸箱包装, 未达到整箱数量以产品量适当采用小型或中型纸箱包装;
3. 因生产Pin位未齐全, 每袋与整箱包装数量仅供参考, 具体包装数量以实际出货为准, 或批量出货更新后为准;

纸箱型号 Carton Type	小型 Small Size	中型 Medium	标准型 Standard	大型 Large
长度 Long (CM)	35	35	35	46
宽度 Wide (CM)	35	35	35	46
高度 Hight (CM)	7.5	15	32	46



CKT	PCS/BAG	CKT	PCS/BAG
2	2000	10	500
3	2000	11	500
4	2000	12	500
5	1000	13	500
6	1000	14	300
7	1000	15	300
8	1000	16	300
9	500		

REV.	REVISION RECORD	DATE	UNIT: mm	GENERAL TOLERANCES		SCALE: 1:1	NAME	DATE	PART.NO:	DWG.NO:	WanLian Technology Co., Ltd
A0	NEW RELEASE	22.03.19			LINEAR	ANGLES	APPROVED	马永波	25.2.19	A2009W92-2XX1XXX	
A1	PA6T IS CHANGED TO PA10T	25.02.19		0.0±0.35	X'REF±6°	CHECK	丁浩	25.2.19	TITLE: Pitch 2.0mm 90° 双排 DIP Wafer	REV: A1	SHEET: 2/2
				0.00±0.25	X'±3°	DRAWN	黄自雄	25.2.19			
			SIZE: A4	0.000±0.10	X'X' ±2°						