

The product using material and processing must conform to the "WI-PZ-001"HSF technical standard control requirements

RoHS+HF

Circuit 1

NOTE:

- 1.MATERIAL SPECIFICATION:
  - 1-1.HOUSING: LCP,UL94V-0
  - 1-2.CONTACTS: BRASS
- 2.PLATING SPECIFICATION:
  - 2-1.CONTACTS: TIN/GOLD FLASH PLATED OVER ALL.
- 3.MECHANICAL PERFORMANCE:
  - 3-1.RETENTIVITY FORCE: 1.0kgf/pin min
  - 3-2.DURABILITY: 50 CYCLES.
- 4.ELECTRICAL PERFORMANCE:
  - 4-1.CURRENT RATING: 3A
  - RATED VOLTAGE : 350V AC/DC
  - 4-2.CONTACT RESISTANCE: 20 mΩ MAX
  - 4-3.INSULATION RESISTANCE: 1000MΩ Min
  - 4-4.DIELECTRIC WITHSTANDING : 500V
- 5.ENVIRONMENTAL PERFORMANCE:
  - 5-1.OPERATING TEMPERATURE: -25°C~+85°C.
- 6.PACKAGE SPEC: REEL
- 7.P/N:

**A1** A1502 W 9 1-1 XX 2 X X 0  
 SERIES NO: \_\_\_\_\_  
 CONNECTOR: \_\_\_\_\_  
 W-WAFER  
 ANGLE: \_\_\_\_\_  
 9-90°  
 TYPE: \_\_\_\_\_  
 1-TYPE 1  
 ROW NO: \_\_\_\_\_  
 1-SINGLE ROW  
 COLOR:  
 A-BLACK  
 S-NATURE  
 PLATING:  
 A-ALL AU G/F  
 C-BRIGHE TIN  
 D-MATTE Tin  
 TERMPIPOINT:  
 2-SMT  
 PIN Q' PY:  
 02~08

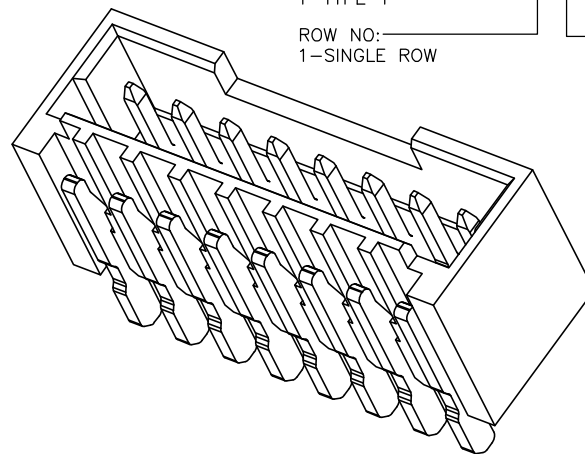
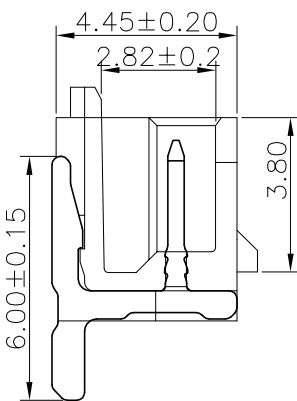
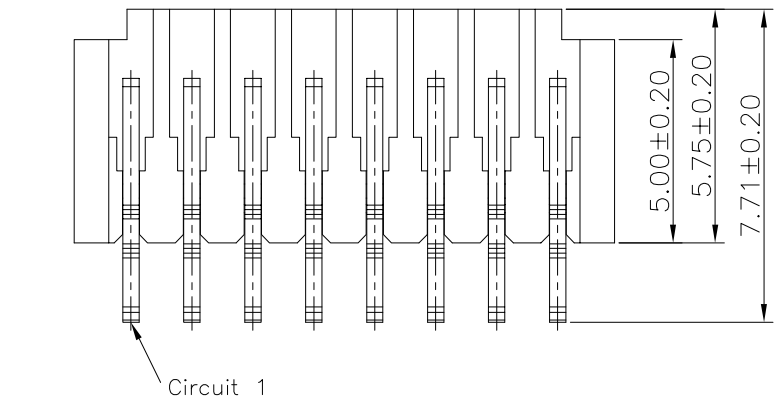
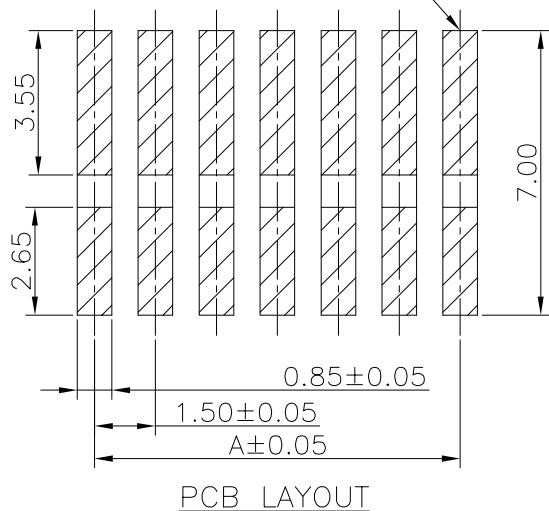
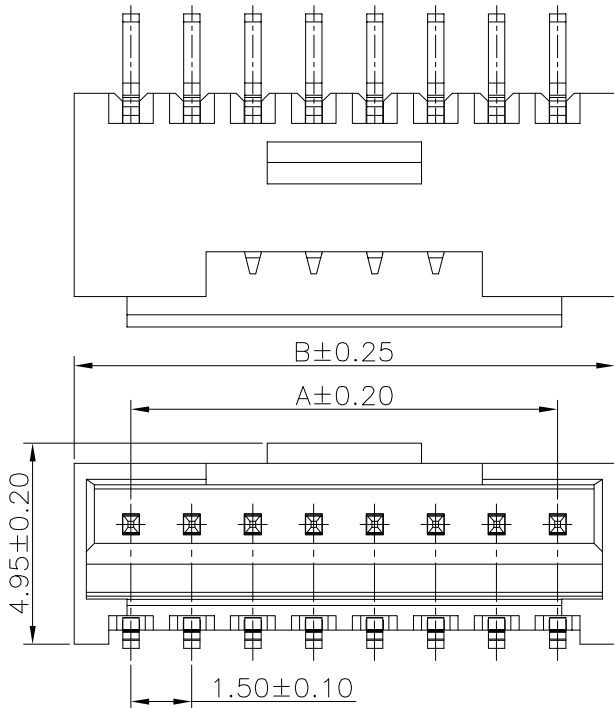

Circuit	Dimensions(mm)	
	A	B
02P	1.50	4.30
03P	3.00	5.80
04P	4.50	7.30
05P	6.00	8.80
06P	7.50	10.30
07P	9.00	11.80
08P	10.50	13.30

REV.	REVISION RECORD	DATE	GENERAL TOLERANCES		SCALE:	NAME	DATE	PART.NO:	DWG.NO:
AO	NEW RELEASE	21.10.12	LINEAR	ANGLES	1:1	Wang_jr	23.09.20	A1502W91-1XX2XX0	ENDE05
A1	PART NUMBER RENEWAL	23.09.20	0.0±0.35	X'REF±6°	APPROVED	Han_Gao	23.09.20	TITLE: Pitch 1.50mm 90° 单排卧贴带扣	 WanLian Technology Co., Ltd
			0.00±0.25	X'±3°	DESIGNER	Zijun_Huang	23.09.20		
			0.000±0.10	X'X' ±2°	DRAWN				
			UNIT: mm					REV: A1	SHEET: 1/2

The product using material and processing must conform to the "WI-PZ-001"HSF technical standard control requirements

RoHS+HF

### 2~10 Contacts

### 11~15 Contacts

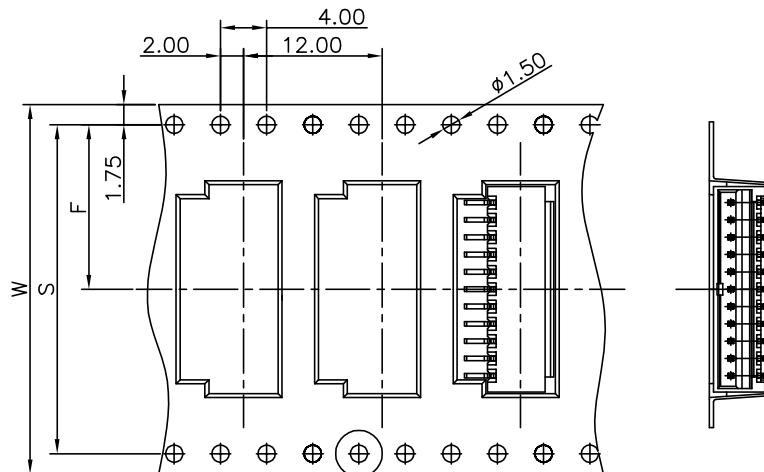
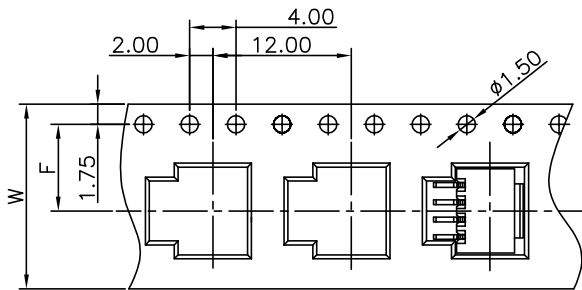

Unreeling direction →

Unreeling direction →

Carrier tape

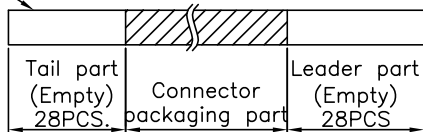

Circuit	W±0.3	F±0.1	S±0.1	Q'ty/Reel
02P	16	5.50		1,000
03P	16	7.50		1,000
04P	16	7.50		1,000
05P	24	11.50		1,000
06P	24	11.50		1,000
07P	24	11.50		1,000
08P	24	11.50		1,000
09P	24	11.50		1,000
10P	24	11.50		1,000
11P	32	14.20	28.40	1,000
12P	32	14.20	28.40	1,000
13P	32	14.20	28.40	1,000
14P	44	20.20	40.40	1,000
15P	44	20.20	40.40	1,000

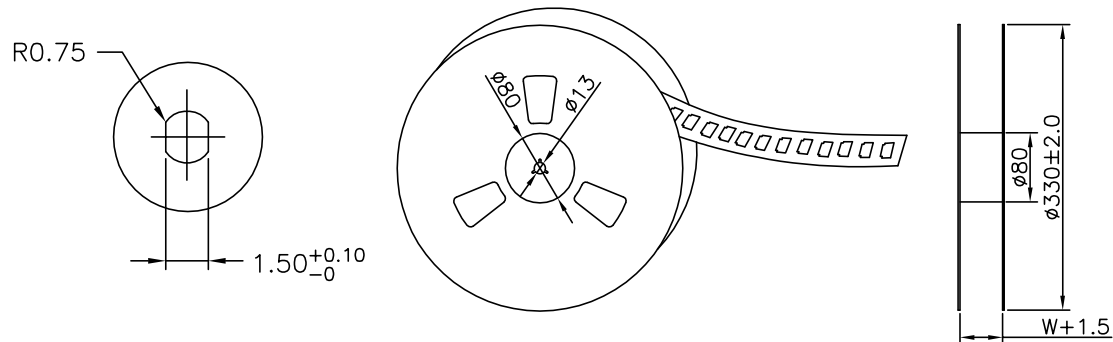

REV.	REVISION RECORD	DATE	UNIT: mm	SIZE: A4
A0	NEW RELEASE	21.10.12		
A1	PART NUMBER RENEWAL	23.09.20		

GENERAL TOLERANCES	
LINEAR	0.00±0.25
ANGLES	X°X' ±2'

SCALE:	NAME	DATE
1:1	Wang_jr	23.09.20
APPROVED	Han_Gao	23.09.20
DESIGNER	Zijun_Huang	23.09.20

PART.NO:	DWG.NO:
A1502W91-1XX2XX0	ENDE05
TITLE: Pitch 1.50mm 90° 单排卧贴带扣/不带扣 包装规范	

WanLian Technology Co., Ltd

REV: A1 SHEET: 2/2