

The product using material and processing must conform to the "WI-PZ-001" HSF technical standard control requirements

RoHS+HF

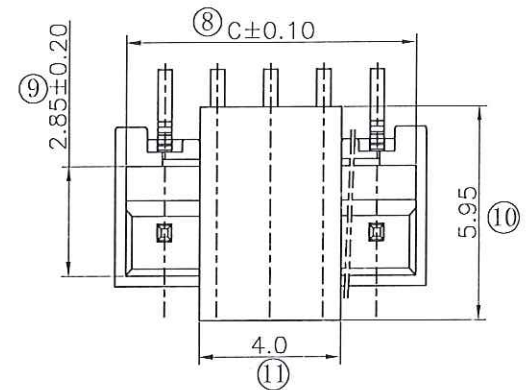

RECOMMENDED PCB LAYOUT
(GENERAL TOLERANCE: ± 0.05)

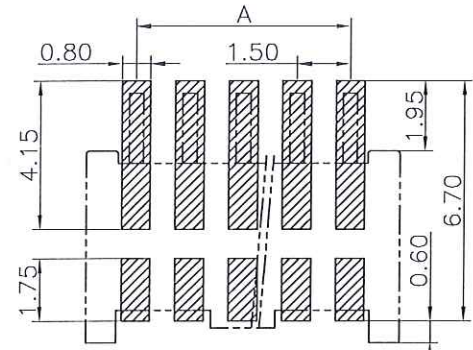
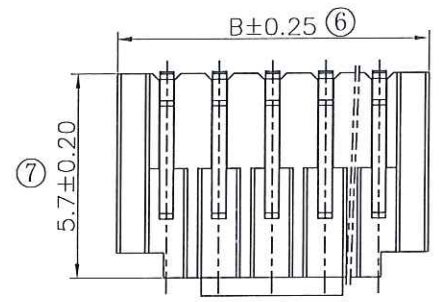
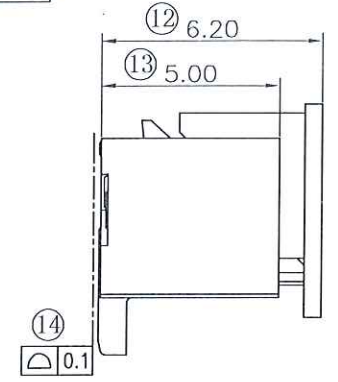
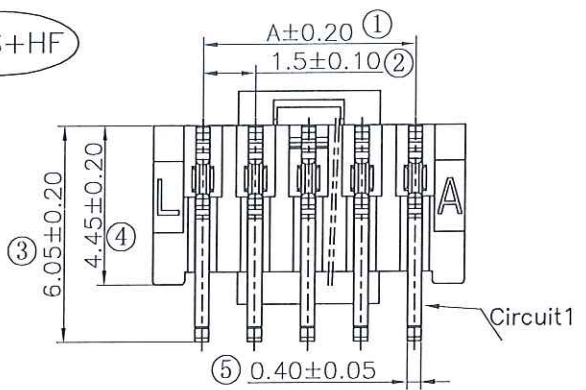
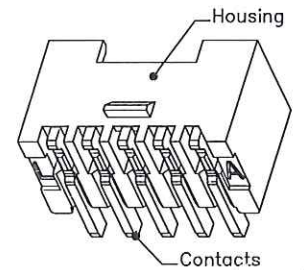

3D VIEWS

- NOTE:
- MATERIAL SPECIFICATION:
 - 1-1. HOUSING: LCP, UL94V-0
 - 1-2. CONTACTS: PHOSPHOR BRONZE
 - PLATING SPECIFICATION:
 - 2-1. CONTACTS: TIN/GOLD FLASH PLATED OVER ALL.
 - ELECTRICAL PERFORMANCE:
 - 3-1. CURRENT RATING: 3A AC/DC
 - 3-2. CONTACT RESISTANCE: 20 mΩ MAX
 - 3-3. INSULATION RESISTANCE: 1000MΩ Min
 - 3-4. DIELECTRIC WITHSTANDING: 500V
 - ENVIRONMENTAL PERFORMANCE:
 - 4-1. OPERATING TEMPERATURE: $-25^{\circ}\text{C} \sim +85^{\circ}\text{C}$.
 - PACKAGE SPEC: REEL
 - P/N:

△ A1
SERIES NO: A1502 W 0 1-1 XX 2 X X 1
CONNECTOR: W-WAFER
ANGLE: 0-180°
TYPE: 1-TYPE 1
ROW NO: 1-SINGLE ROW
COLOR: A-BLACK, S-NATURE
PLATING: A-ALL AU G/F, C-BRIGHE TIN, D-MATTE Tin
TERMIPOINT: 2-SMT
PIN Q'PY: 02~15

Circuit	Dimensions(mm)			Circuit	Dimensions(mm)		
	A	B	C		A	B	C
02	1.50	4.30	3.70	09	12.00	14.80	14.20
03	3.00	5.80	5.20	10	13.50	16.30	15.70
04	4.50	7.30	6.70	11	15.00	17.80	17.20
05	6.00	8.80	8.20	12	16.50	19.30	18.70
06	7.50	10.30	9.70	13	18.00	20.80	20.20
07	9.00	11.80	11.20	14	19.50	22.30	21.70
08	10.50	13.30	12.70	15	21.00	23.80	23.20

REV.	REVISION RECORD	DATE	GENERAL TOLERANCES	SCALE: 1:1	NAME	DATE	PART.NO:	DWG.NO:	 WanLian Technology Co., Ltd
A0	NEW RELEASE	22.07.07	LINEAR	APPROVED	B/2/p	2024.6.25	A1502W01-1XX2XX1	ENDE05	
A1	PART NUMBER RENEWAL		0.0±0.35	DESIGNER	梁林积	2024.6/25	TITLE:	REV: A1	
			0.00±0.25	DRAWN	肖雨曦	2024.6.25	Pitch 1.50mm 180° 单排立贴带扣 Wafer	SHEET: 1/2	

The product using material and processing must conform to the "WI-PZ-001"HSF technical standard control requirements

RoHS+HF

产品引出方向

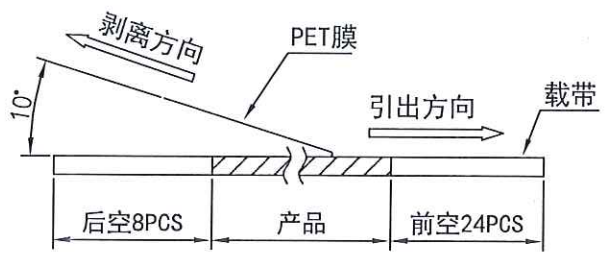
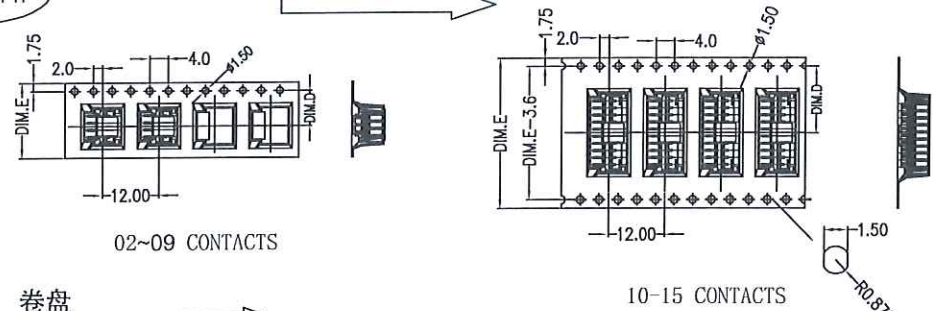

(PET膜剥离示意图)

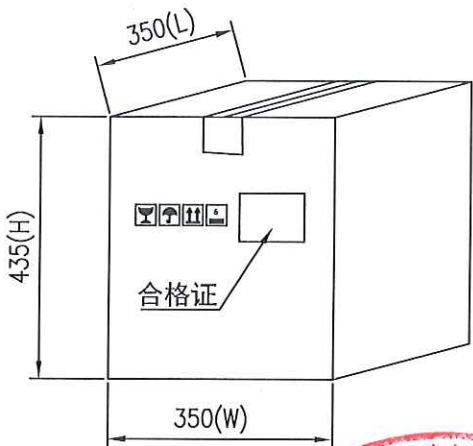
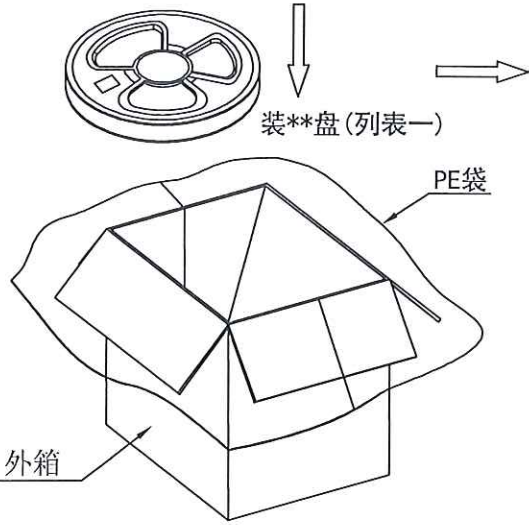
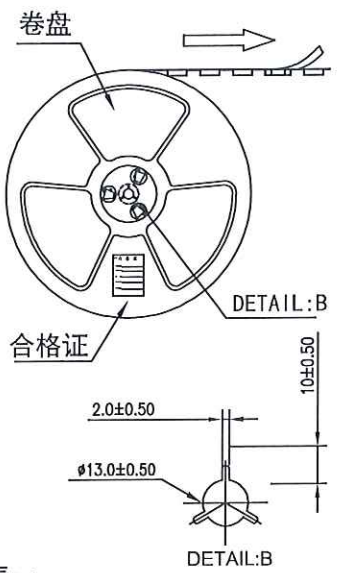

列表一

Circuits	DIM. D	DIM. E	Q'ty/Reel	Packing (Reel/Caton)
02~04PIN	7.5	16	800PCS	20/Reel
05~09PIN	11.50	24	800PCS	15/Reel
10~13PIN	14.20	32	800PCS	11/Reel
14~16PIN	20.20	44	800PCS	8/Reel

包装说明:
 1. 把成品包入卷盘中, 每盘装800PCS, 卷盘上贴上合格证, 将装好产品的卷盘放进外箱中, 外箱内先套一个大PE袋, 外箱上贴贴上合格证。
 2. 所有材料有害物控制需符合RoHS标准。



REV.	REVISION RECORD	DATE	UNIT:mm	GENERAL TOLERANCES	SCALE: 1:1	NAME	DATE	PART.NO:	DWG.NO:	 WanLian Technology Co., Ltd	
A0	NEW RELEASE	22.07.07		LINEAR				A1502W01-1XX2XX1	ENDE05		
A1	PART NUMBER RENEWAL			0.0±0.35	X'REF±6'	梁林双	2024.6.25				
				0.00±0.25	X'±3'	梁林双	2024.6.25	TITLE:			
				0.000±0.10	X'X' ±2'	肖雨曦	2024.6.25	Pitch 1.50mm 180° 单排立贴带扣 Wafer包装规范		REV: A1	SHEET: 2/2