

The product using material and processing must conform to the "WI-PZ-142"HSF technical standard control requirements

RoHS+HF

NOTE:
 1.MATERIAL SPECIFICATION:
 1-1.HOUSING:LCP NATURE UL94V-0
 1-2.SOLDER TABS:PHOSPHOR BRONZE
 1-3.CONTACTS:PHOSPHOR BRONZE
 2.PLATING SPECIFICATION:
 2-1.CONTACTS:
 TIN/AU PLATED OVER ALL.
 4.ELECTRICAL PERFORMANCE:
 4-1. RATED CURRENT : 1A AC,DC
 4-2.INSULATION RESISTANCE: 100MΩ MIN
 4-3.CONTACT RESISTANCE : 30mΩ(MAX.)
 4-4.WITHSTANDING VOLTAGE: 500V AC/minute
 5.ENVIRONMENTAL PERFORMANCE:
 OPERATING TEMPERATURE: -40°C~+105°C.
 6.PACKAGE SPEC: REEL
 7.P/N:

△ A1257 W 9-1 XX 2 X X 0
 SERIES NO:
 CONNECTOR:
 W-WAFER
 ANGLE:
 9-90°
 ROW NO:
 1-SINGLE ROW
 PIN Q'PY:
 02~20
 COLOR:
 A-BLACK
 S-NATURE
 PLATING:
 A-ALL AU G/F
 C-BRIGHT TIN
 D-MATTE TIN
 TERMIPOINT:
 2-SMT

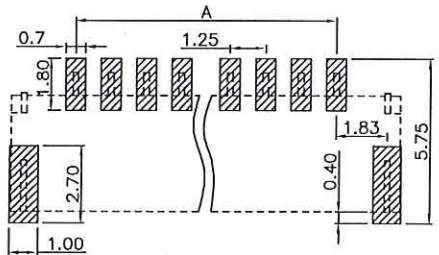
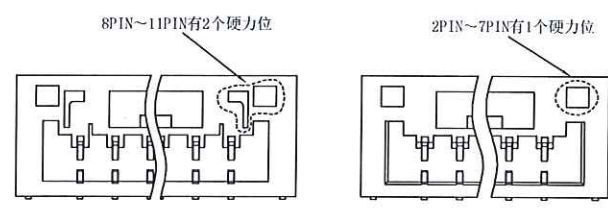
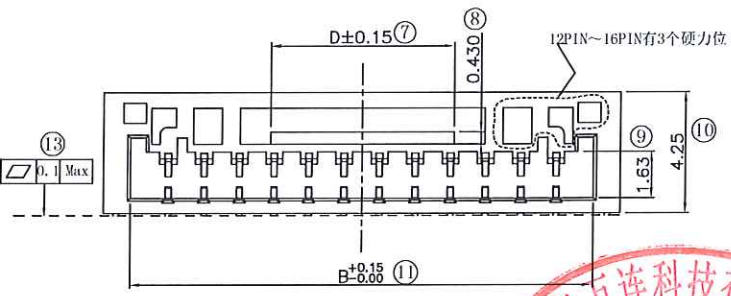
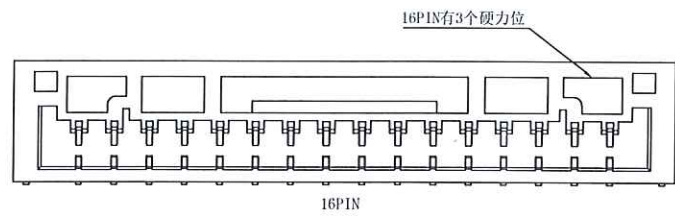
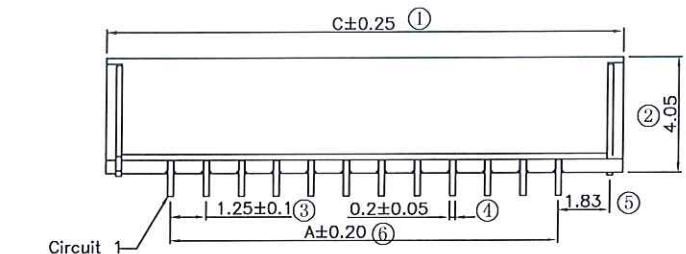

RECOMMENDED PCB LAYOUT
 (GENERAL TOLERANCE:±0.05)

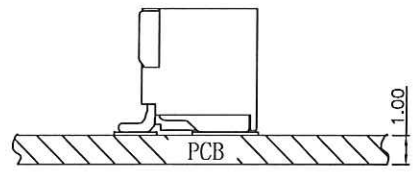
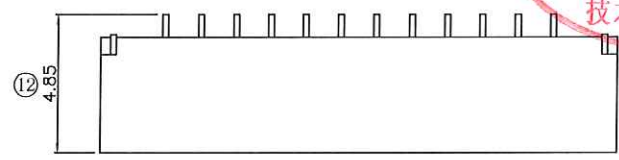

东方连科技有限公司
 2024.06.20
 产品中心
 技术文件发行章

Ordering Information & Dimensions

Circuit	Dimensions(mm)				Circuit	Dimensions(mm)			
	A	B	C	D		A	B	C	D
02	1.25	3.85	5.80	0.50	12	13.75	16.35	18.30	6.50
03	2.50	5.10	7.05	1.75	13	15.00	17.60	19.55	6.50
04	3.75	6.35	8.30	2.00	14	16.25	18.85	20.80	6.50
05	5.00	7.60	9.55	3.26	15	17.50	20.10	22.05	6.50
06	6.25	8.85	10.80	4.52	16	18.75	21.35	23.30	6.50
07	7.50	10.10	12.05	4.50	17	20.00	22.60	24.55	6.50
08	8.75	11.35	13.30	4.50	18	21.25	23.85	25.80	6.50
09	10.00	12.60	14.55	4.50	19	22.50	25.10	27.05	6.50
10	11.25	13.85	15.80	6.50	20	23.75	26.35	28.30	6.50
11	12.50	15.10	17.05	6.50					

REV.	REVISION RECORD	DATE		GENERAL TOLERANCES		SCALE: 1:1	NAME	DATE	PART.NO:	DWG.NO:	 WanLian Technology Co., Ltd
A0	NEW RELEASE	21.01.13		LINEAR	ANGLES	APPROVED	梁林和	2024.6.20	A1257W9-1XX2XX0	ENDE05	
A1	PART NUMBER RENEWAL			0.0±0.35	X'REF±6'	DESIGNER	梁林和	2024.6.20	TITLE:	GH1.25 FLAT ATTACHMENT CONNECTOR	
				UNIT:mm	0.00±0.25	X'±3'	DRAWN	肖雨薇	2024.6.20		
			SIZE: A4	0.000±0.10	X'X' ±2'					REV: A1	SHEET: 1/2

The product using material and processing must conform to the "WI-PZ-142"HSF technical standard control requirements

RoHS+HF

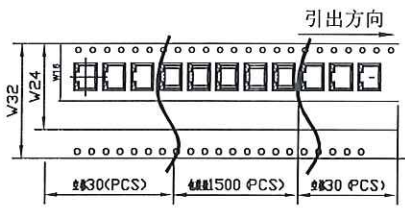
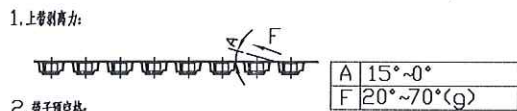
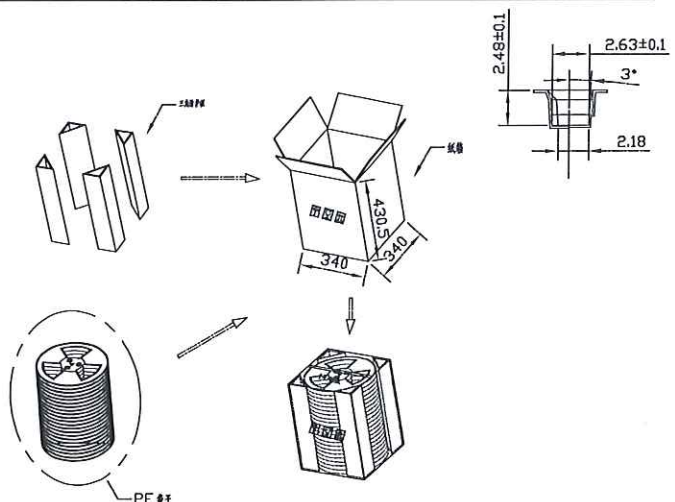
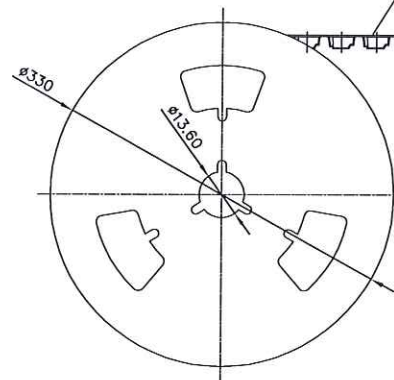
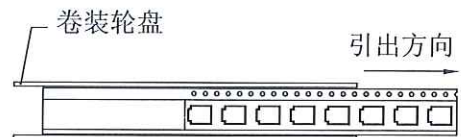
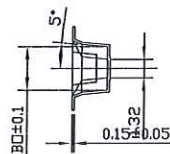
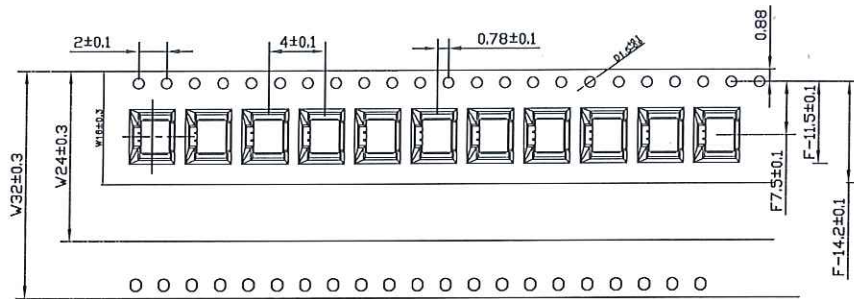

Circuits	载带尺寸			Circuits	载带尺寸			卷装包装明细表			
	W	B0	F		W	B0	F	PIN位	每卷包装数	每盘数量	每件数量
02P	16.0	6.10	7.50	012P	32.0	18.6	14.2	02P-04P	1500(PCS)	20 (盘)	30(K)
03P	16.0	7.35	7.50					05P-10P	1500(PCS)	14 (盘)	21(K)
04P	16.0	8.60	7.50					11P-14P	1500(PCS)	11 (盘)	16.5(K)
05P	24.0	9.85	11.50					15P-16P	1500(PCS)	8 (盘)	12(K)
06P	24.0	11.10	11.50								
07P	24.0	12.35	11.50								
08P	24.0	13.60	11.50								
09P	24.0	14.85	11.50								
10P	24.0	16.10	11.50								
11P	32.0	17.35	14.20								

REV.	REVISION RECORD	DATE		GENERAL TOLERANCES		SCALE: 1:1	NAME	DATE	PART.NO:	DWG.NO:	 WanLian Technology Co., Ltd
A0	NEW RELEASE			LINEAR	ANGLES	APPROVED	梁林积	2024.6.20	A1257W9-1XX2XX0	ENDE05	
			UNIT:mm	0.00±0.25	X'REF±6'	DESIGNER	梁林积	2024.6.20	TITLE:		REV: A0 SHEET: 2/2
			SIZE: A4	0.000±0.10	X'X' ±2'	DRAWN	肖雨峰	2024.6.20	GH1.25 VERTICAL CONNECTOR		