

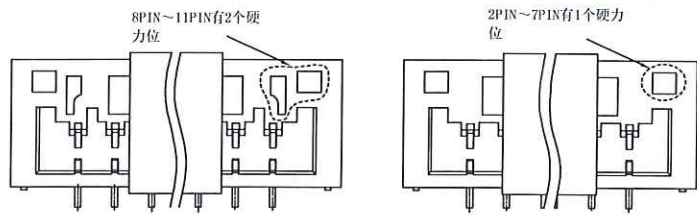

RoHS+HF

The product using material and processing must conform to the "WI-PZ-142" HSF technical standard control requirements

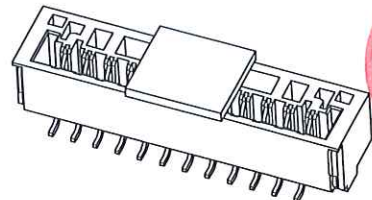
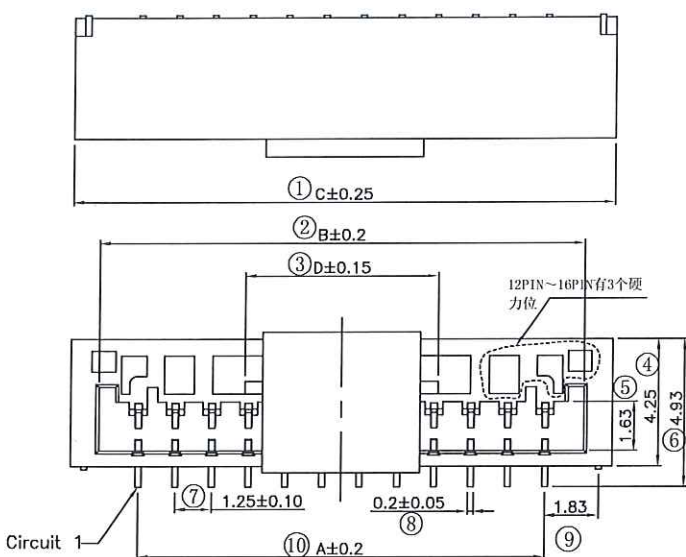

- NOTE:
- MATERIAL SPECIFICATION:
 - 1-1.HOUSING:LCP NATURE UL94V-0
 - 1-2.SOLDER TABS:PHOSPHOR BRONZE
 - 1-3.CAP:LCP NATURE UL94V-0
 - 1-4.CONTACTS:PHOSPHOR BRONZE
 - PLATING SPECIFICATION:
 - 2-1.CONTACTS: TIN/AU PLATED OVER ALL.
 - ELECTRICAL PERFORMANCE:
 - 4-1. RATED CURRENT : 1A AC,DC
 - 4-2.INSULATION RESISTANCE: 100MΩ MIN
 - 4-3.CONTACT RESISTANCE : 30mΩ(MAX.)
 - 4-4.WITHSTANDING VOLTAGE: 500V AC/minute
 - ENVIRONMENTAL PERFORMANCE:
 - OPERATING TEMPERATURE: -40°C~+105°C.
 - PACKAGE SPEC: REEL
 - P/N:

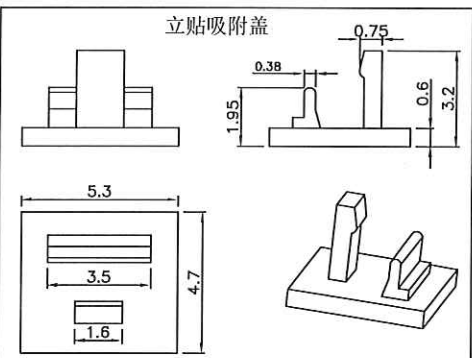
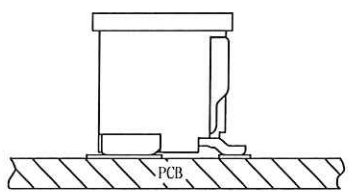
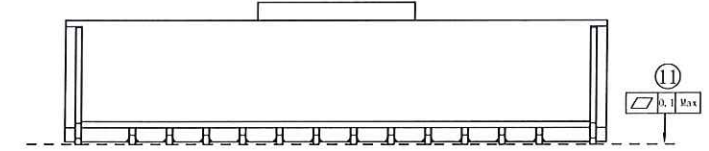
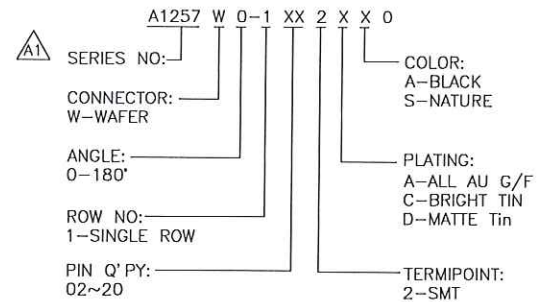
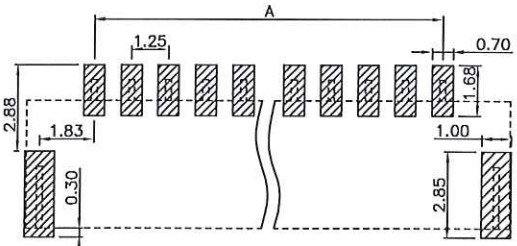

Ordering Information & Dimensions

Circuit	Dimensions(mm)				Circuit	Dimensions(mm)			
	A	B	C	D		A	B	C	D
02	1.25	3.85	5.80	0.50	12	13.75	16.35	18.30	6.50
03	2.50	5.10	7.05	1.75	13	15.00	17.60	19.55	6.50
04	3.75	6.35	8.30	2.00	14	16.25	18.85	20.80	6.50
05	5.00	7.60	9.55	3.26	15	17.50	20.10	22.05	6.50
06	6.25	8.85	10.80	4.52	16	18.75	21.35	23.30	6.50
07	7.50	10.10	12.05	4.50	17	20.00	22.60	24.55	6.50
08	8.75	11.35	13.30	4.50	18	21.25	23.85	25.80	6.50
09	10.00	12.60	14.55	4.50	19	22.50	25.10	27.05	6.50
10	11.25	13.85	15.80	6.50	20	23.75	26.35	28.30	6.50
11	12.50	15.10	17.05	6.50					

REV.	REVISION RECORD	DATE		GENERAL TOLERANCES		SCALE: 1:1	NAME	DATE	PART.NO:	DWG.NO:	 WanLian Technology Co., Ltd
A0	NEW RELEASE	21.01.13		LINEAR	ANGLES	APPROVED	马学洋	2024.6.20	A1257W0-1XX2XX0	ENDE05	
A1	PART NUMBER RENEWAL	23.09.19		0.0±0.35	X'REF±6'	DESIGNER	梁林积	2024.6.20	TITLE:		
				UNIT:mm	0.00±0.25	X'±3'	DRAWN	肖雨曦	2024.6.20	GH1.25 VERTICAL CONNECTOR	
			SIZE: A4	0.000±0.10	X'X' ±2'						

The product using material and processing must conform to the "WI-PZ-142"HSF technical standard control requirements

RoHS+HF

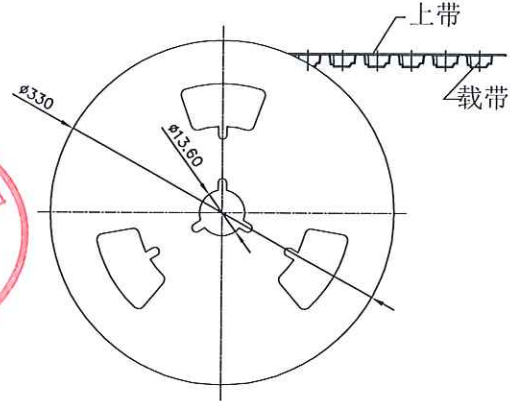
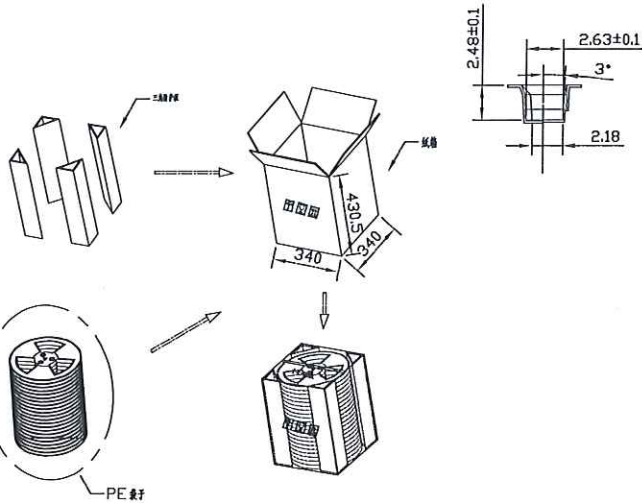
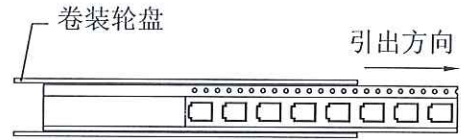
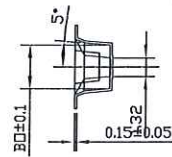
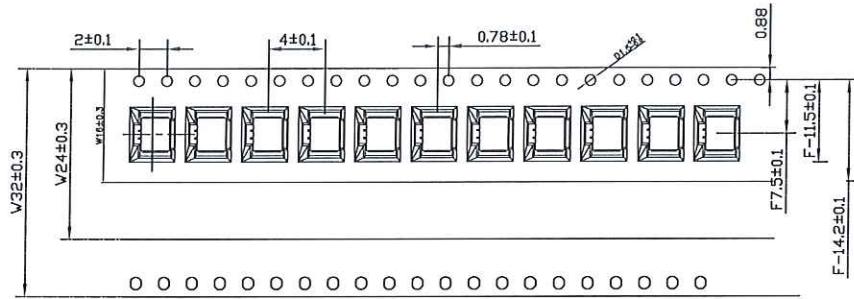

1. 上带剥离力:

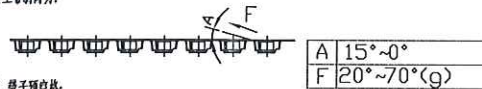

2. 端子锁空格:

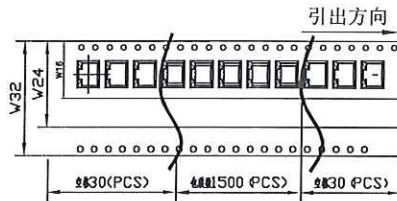

3. 载带材料规格: PS 白色料抗静电, 厚度 0.30mm.

Circuits	规格尺寸			Circuits	规格尺寸			包装规格和数量			
	W	B0	F		W	B0	F	PIN数	每卷包装数量	零件数量	零件重量
02P	16.0	6.10	7.50	012P	32.0	18.6	14.2	02P-04P	1500(PCS)	20 (4)	30(K)
03P	16.0	7.35	7.50					05P-10P	1500(PCS)	14 (4)	21(K)
04P	16.0	8.60	7.50					11P-14P	1500(PCS)	11 (4)	16.5(K)
05P	24.0	9.85	11.50					15P-16P	1500(PCS)	8 (4)	12(K)
06P	24.0	11.10	11.50								
07P	24.0	12.35	11.50								
08P	24.0	13.60	11.50								
09P	24.0	14.85	11.50								
010P	24.0	16.10	11.50								
011P	32.0	17.35	14.20								

REV.	REVISION RECORD	DATE		GENERAL TOLERANCES		SCALE: 1:1	NAME	DATE	PART.NO:	DWG.NO:	 WanLian Technology Co., Ltd
A0	NEW RELEASE	21.01.13		LINEAR	ANGLES	APPROVED	陈学洋	2024.6.20	A1257W0-1XX2XX0	ENDE05	
A1	PART NUMBER RENEWAL			0.0±0.35	X'REF±6°	DESIGNER	梁林权	2024.6.20	TITLE:		
				UNIT:mm	0.00±0.25	X'±3°	DRAWN	肖雨羲	2024.6.20	GH1.25 VERTICAL CONNECTOR	
			SIZE: A4	0.000±0.10	X'X' ±2°						