

The product using material and processing must conform to the "WI-PZ-142"HSF technical standard control requirements

RoHS

- NOTE:
- 1.MATERIAL SPECIFICATION:
1-1.TERMINAL:PHOSPHOR BRONZE
 - 2.PLATING SPECIFICATION:
2-1.TERMINAL:
TIN PLATED OVER ALL.
 - 3.ELECTRICAL PERFORMANCE:
3-1. RATED CURRENT : 1A AC,DC
3-2.INSULATION RESISTANCE: 100MΩ MIN
3-3.CONTACT RESISTANCE : 20mΩ(MAX.)
3-4.WITHSTANDING VOLTAGE: 500V AC/minute
 - 4.ENVIRONMENTAL PERFORMANCE:
OPERATING TEMPERATURE: -25°C~+85°C.
 - 5.P/N:

SERIES NO: A1002 T F X-X
CONNECTOR: T-TERMINAL
MALE FEMALE: F-FEMALE

PLATING:
1-G/F
A-ALL AU G/F
C-BRIGHT TIN
H-ALL-AU 15U"

METAL:
P-PHOSPHOR BRONZE
B-BRASS

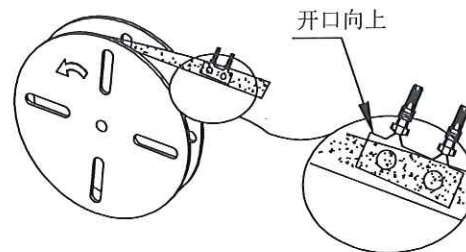

Ordering Information & Specifications

Wire Range	Qty/reel
AWG28#-32#	20,000pcs

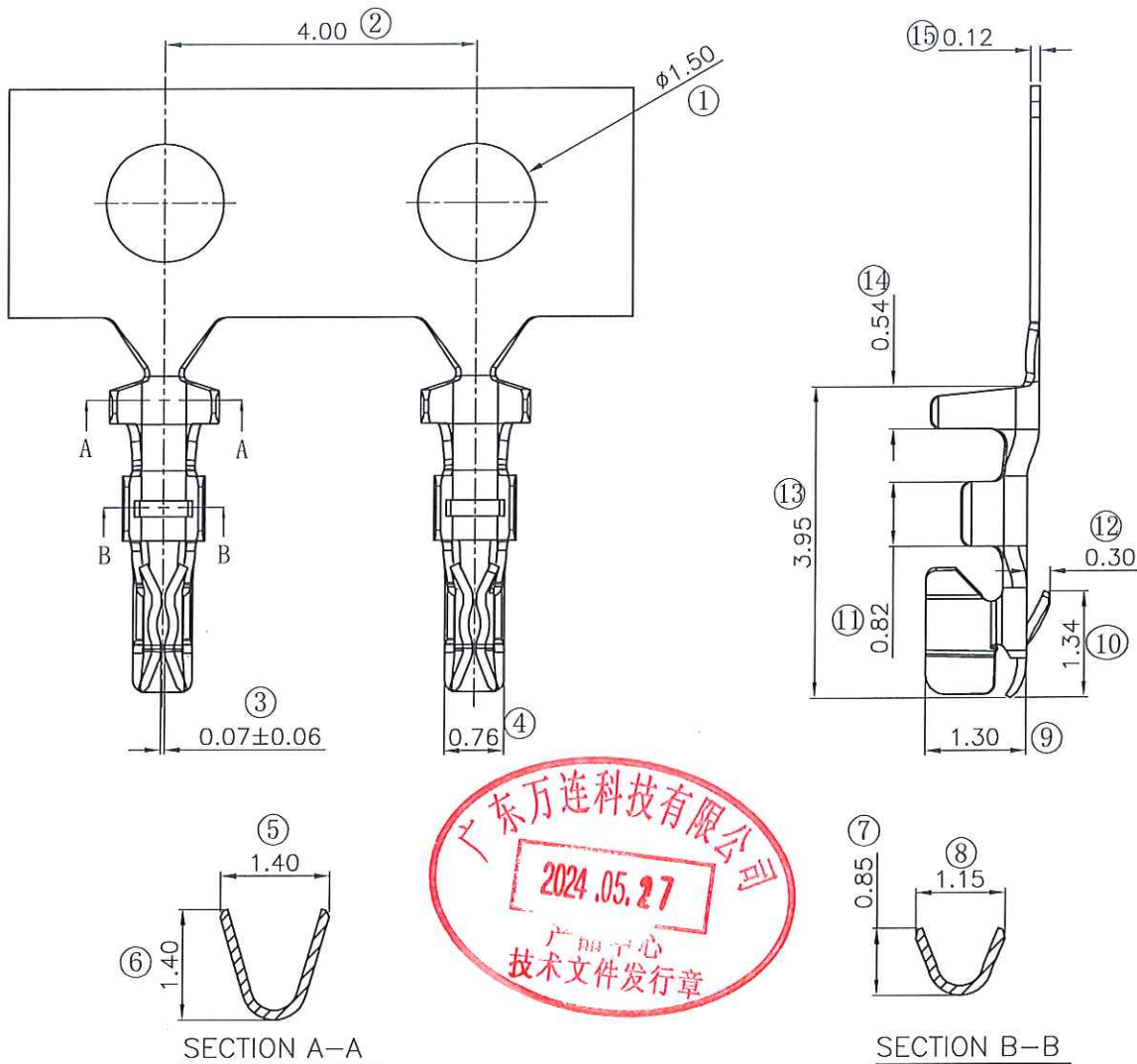

REV.	REVISION RECORD	DATE		GENERAL TOLERANCES		SCALE: 1:1	NAME	DATE	PART.NO:	DWG.NO:	 WanLian Technology Co., Ltd
A0	NEW RELEASE			LINEAR	ANGLES	APPROVED	梁林积	2024.5.27	A1002TFX-X	ENDE05	
			UNIT:mm	0.00±0.25	X'±3'	DESIGNER	梁林积	2024.5.27	TITLE:		REV: A0
			SIZE: A4	0.000±0.10	X'X' ±2'	DRAWN	肖雨晴	2024.5.27	Pitch1.0mm SH端子 AWG#28~#32		SHEET: 1/1