

The product using material and processing must conform to the "WI-PZ-001"HSF technical standard control requirements

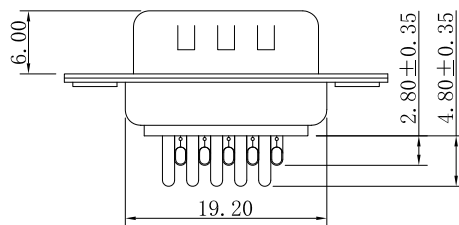
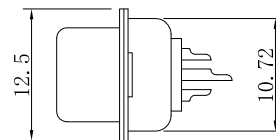

CHARACTERISTICS:

- 1、 RATED VOLTAGE: 250V AC CD
- 2、 RATED CURRENT: 3.0AMP
- 3、 CONTACT RESISTANCE: 30mΩ Max.
- 4、 INSULATION RESISTANCE: 1000 MΩ MIN. 500V DC
- 5、 Electric Pressure: Keeping 60 second in AC 500V/1mA
- 6、 Operating temperature: -55℃~105℃
- 7、 INSERTION/EXTRACTION FORCE PER CONTACT: 3.74Kg Max
0.33Kg Min.

Specification Type

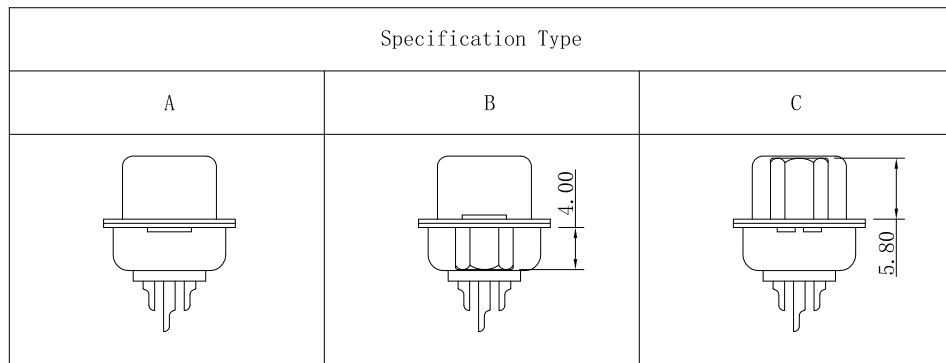

ORDER INFORMTION

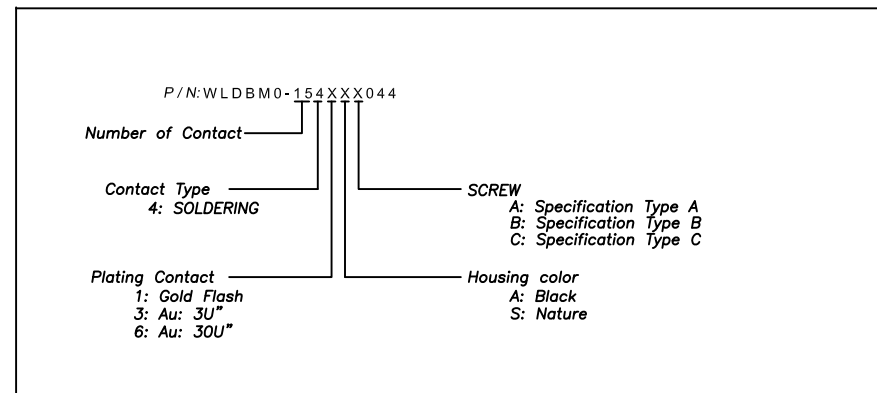

REV.	REVISION RECORD	DATE		GENERAL TOLERANCES		SCALE: 1:1	NAME	DATE	PART. NO:	DWG. NO:	 WanLian Teconology Co., Ltd
A0	NEW RELEASE	21.01.13		LINEAR	ANGLES	APPROVED	Wang_jr	21.03.11	WLDBM0-154XXX044	ENDE05	
			0.0±0.35	X° REF±6°	DESIGNER	Ding_Bo	21.03.11	TITLE:			
			UNIT: mm	0.00±0.25	X° ±3°	DRAWN	Ou_Jian	21.03.11	HDB 15M SOLDERING		
			SIZE: A4	0.000±0.10	X° X'±2°				REV: A0	SHEET: 1/1	